

3.0 Installation

Contents

3.1	Before Installation - Location Considerations.....	3-1
3.2	Physical Access and Thermal Clearance	3-2
3.3	Projector-to-Screen Alignment	3-4
3.4	Lens Selection	3-5
3.5	System Connections	3-13
3.6	Video Sources.....	3-15
3.7	Front/Rear or Inverted Vertical Projection	3-17
	3.7.1 Front/Rear Jumper Setting	3-17
	3.7.2 Inverted Vertical Jumper Settings.....	3-18
3.8	Connections Checklist.....	3-19

3.1 Before Installation - Location Considerations

We caution you to take the time now to carefully observe the requirements for optimum projector setup. The Series 300 is an advanced projector that delivers a premium image, but it **must** be set up correctly in order to run ideally. Improper location and setup now will cause problems later during image adjustment.

Before installing the projector, you must consider the following:

- Front or rear projection
- Table or ceiling mounting
- Projector-to-screen alignment
- Screen size
- Seating arrangements
- Lens size selection
- The Series 300 projector was designed to operate rightside up, not inverted!

3.2 Physical Access and Thermal Clearance

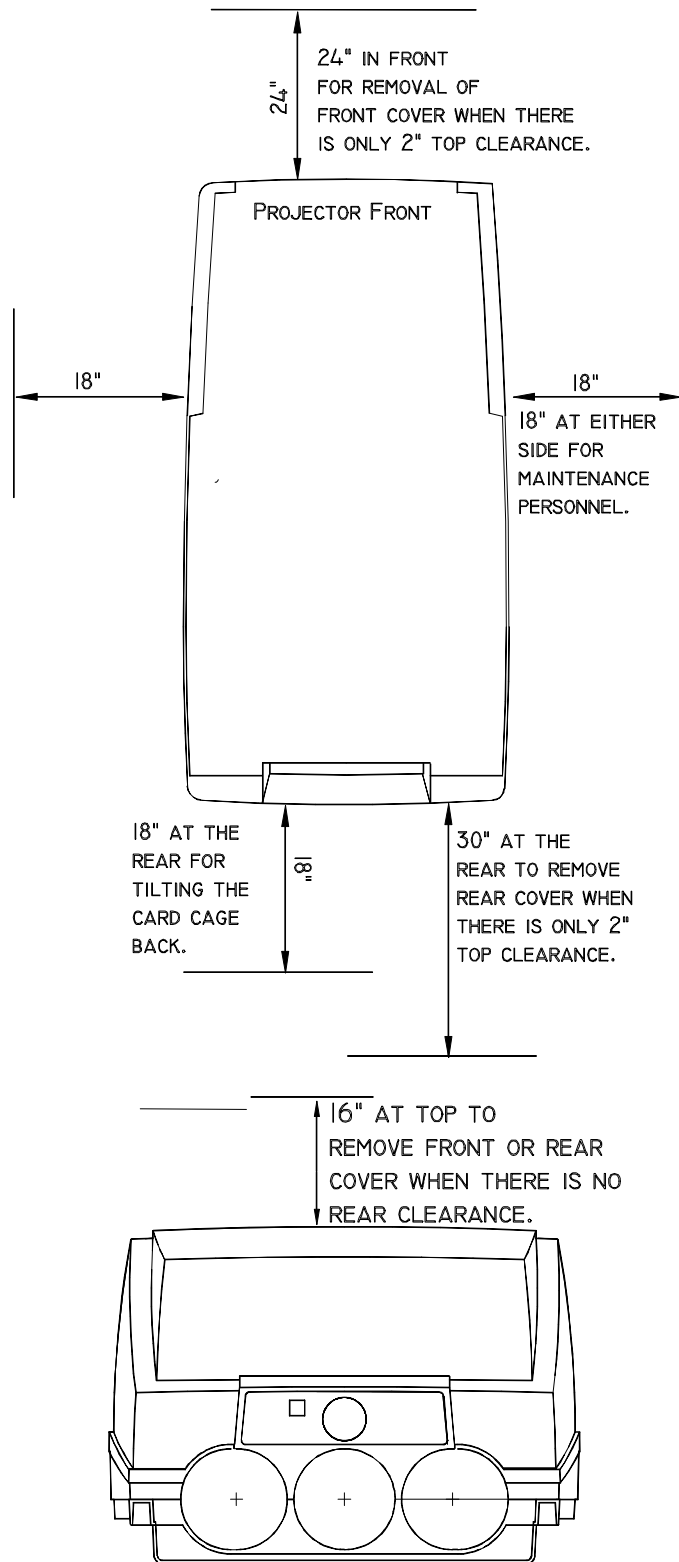

Figure 3-1. Clearances for cover removal and physical access.

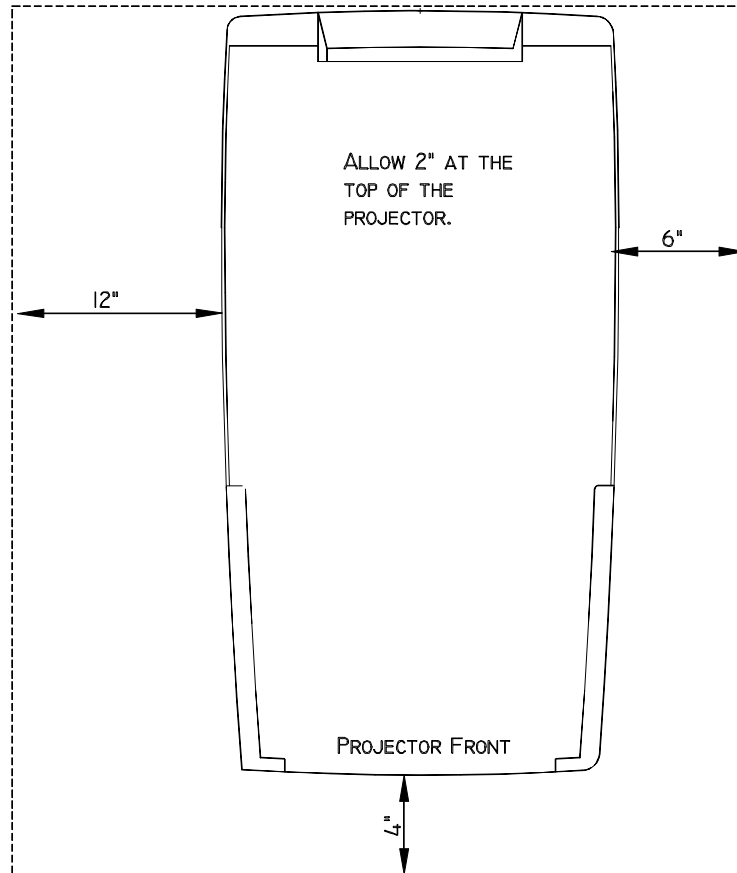

Figure 3-2. Clearances needed for heat dissipation.

The physical access of 18" at the sides of the projector (see *Figure 3-1*) provides a person of average size room to perform maintenance from the sides of the projector after the covers are removed. The front or rear cover access is variable and depends on how much top clearance is provided. With the 2" minimum, a rear clearance of 30" is required. With more top clearance, less rear clearance will be needed and some trial and error may be needed if the projector is installed in close quarters.

Clearances for heat dissipation, shown in *Figure 3-2*, are a minimum for rooms of normal ambient air temperature. Rooms with very hot ambient air temperature (see *Operating Parameters*, page 7-2) may require greater distances to dissipate heat properly. **NOTE:** The projector dissipates 9200btus/hr (12,950/hr for Model 335) and **must not** be placed in an enclosure that would limit air flow. Adequate ventilation (see *Specifications-"Airflow"*, page 7-3) is necessary to provide proper air flow to prevent overheating and allow proper operation.

3.3 Projector-to-Screen Alignment

Set the projector to the proper distance from the screen as determined by the screen width and Lens Throw Ratio being used (see *Lens Section 3.4*). The lens dynamics chart in Section 3.4 below will assist in determining what lens to use for different throw ranges and screen widths.

Whatever mounting method is chosen, the maximum *projector-to-screen* vertical tilt angle is 15° (*Figure 3-3*). Any tilt more than 15° will result in a severe keystone error that cannot be corrected. The maximum *vertical projector tilt* is 85° . **Voids in the prism fluid cause a “dead zone” at $19^\circ \pm 4^\circ$, therefore angles of between 15° and 23° must be avoided.**

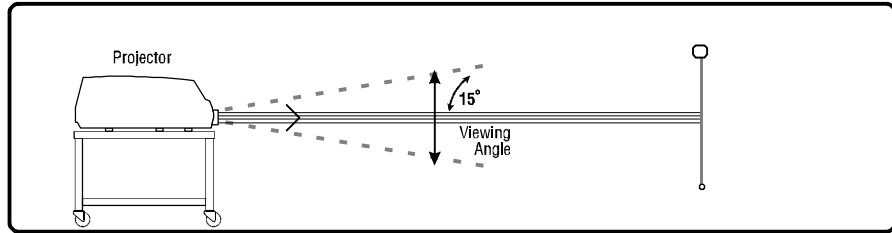

Figure 3-3. Maximum projector-to-screen vertical tilt angle for table mounting, front or rear projection.

Verify that the projector is centered horizontally on the screen, with the front corners equidistant from the screen (*Figure 3-4*).

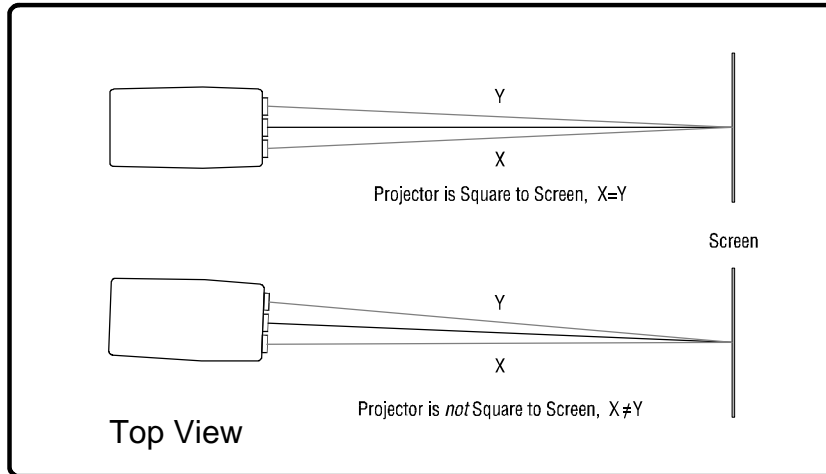

Figure 3-4. Projector should be square to screen.

3.4 Lens Selection

Throw Distance and Screen Width. The Series 300 Projector accommodates ten different lens and converter options. The standard options and most common Lens Throw Ratios in use for Models 315, 320 and 335 are **1.5:1**, **3:1**, **5:1** and **7:1** (corresponding to the **1.875:1**, **3.75:1**, **6.25:1**, and **8.75:1** for the Model 310E). Other lens and converter options that are available are listed in Tables 3-3 and 3-4). The Lens Throw Ratio numbers indicate the Throw Distance to Screen Width ratios. For example the **1.5:1** lens indicates a throw distance of 1.5 times the screen width. An illustration of screen width and throw distance is shown in Figure 3-5. A formula for calculating the effective Lens Throw Ratio (based on the projector setup) for lens set and converter (if necessary) is shown below the illustration.

Information on lens dynamics and lens interchangeability is provided in Tables 3-1 and 3-2 and Figures 3-6 and 3-7 for the four standard types of lenses plus the **.885** special wide angle lenses. Lens matrices are shown in Tables 3-3 and 3-4 for all the various options with their specific part numbers. **NOTE:** The Model 310E shows different types of lenses in Tables 3-1 and 3-2 below. These lenses are the same lenses as noted above for the other projectors but show disparate screen widths due to the different aperture of the **ILA**[®] in the Model 310E projector.

Series 300 Projectors have variable throw distances up to 10 times the screen width. For example the Lens Chart (Figure 3-6) shows that a 10' wide picture can be projected from 15', 30', 50', or up to 70' depending on the lens option chosen. (See *Table 3-1, Lens Dynamics and Figures 3-6 and 3-7, Lens Charts below.*)

Screen width is the maximum size of picture that can be displayed. The series 300 projectors are CRT based and the picture size can be reduced from the maximum. Placement of the projector must be a multiple of Screen Width X Lens Throw Ratio, (or greater), from the closest point to the screen. A greater distance can be corrected for by reducing the picture size within the **ILA**[®] image but the picture size *cannot* be increased beyond the **ILA**[®] image.

Table 3-1. Lens Dynamics:

Models 315, 320 and 335		
Lens Throw Ratio	Throw Range	Screen Width
.885:1	7 - 11.8 ft.	8 - 13.33 ft.
.885:1	11.8 - 17.7 ft.	13.33 - 20 ft.
1.5:1	9.6 - 67.5 ft.	6.4 - 45 ft.*
3:1	15.6 - 135 ft.	5.2 - 45 ft.*
5:1	21 - 210 ft.	4.2 - 45 ft.*
7:1	25.2 - 201 ft.	3.6 - 28.7 ft.
Model 310E		
Lens Throw Ratio	Throw Range	Screen Width
1.1:1	8.8 - 14.66 ft.	8 - 13.33 ft.
1.1:1	14.66 - 22 ft.	13.33 - 20 ft.
1.875:1	9.6 - 75 ft.	5.1 - 40 ft.
3.75:1	15.8 - 150 ft.	4.2 - 40 ft.
6.25:1	21.3 - 210 ft.	3.4 - 40 ft.
8.75:1	24.5 - 201 ft.	2.8 - 23 ft.

*Up to 50' for Projector Model 335.

Lens sets selected are dictated by screen size and room dimensions. Verify that the lenses are mounted in the correct color position (i.e., the **1.5:1** lens requires specific lens for Blue). See Table 3-2, Lens Interchangeability below.

Table 3-2. Lens Interchangeability:

Lens Throw Ratio	Lens Color	Part Number	Lens Position Requirements
.885:1 (Special Order)*	R, G and B have same p/n. Specify color when ordering.	103280 (for 8'-13.33' screen widths)	Specific lens needed for RGB. None interchangeable.
		102692 (for 13.33'-20' screen widths)	
1.5:1	Blue	101715	Specific lens needed for B. R/G interchangeable.
	Red and Green	101241	
3:1	R, G and B have same p/n. Specify color when ordering.	900609	Specific lens needed for RGB. None interchangeable.
5:1	Red, Green and Blue	101239	RGB all interchangeable.
7:1	Red, Green and Blue	101240	RGB all interchangeable.

***2.177:1** and **10:1** lenses are also available by special order. Contact Hughes-JVC for information on these lenses.

Other lens dynamics can be achieved by the use of a **.8** converter which can be used with the **1.5:**, **3:1**, or **5:1** lens (see Tables 3-3, 3-4).

For assistance in choosing a Lens Throw Ratio vs. screen width and screen throw distance, refer to the Lens Charts, Figure 3-6 (for Models 315, 320, and 335) and Figure 3-7 (for Model 310E) and Lens Matrix Tables 3-3 (Models 315, 320, and 335) and 3-4 (Model 310E). Use the charts and tables as an aid in choosing the correct lens for a given screen width or throw distance.

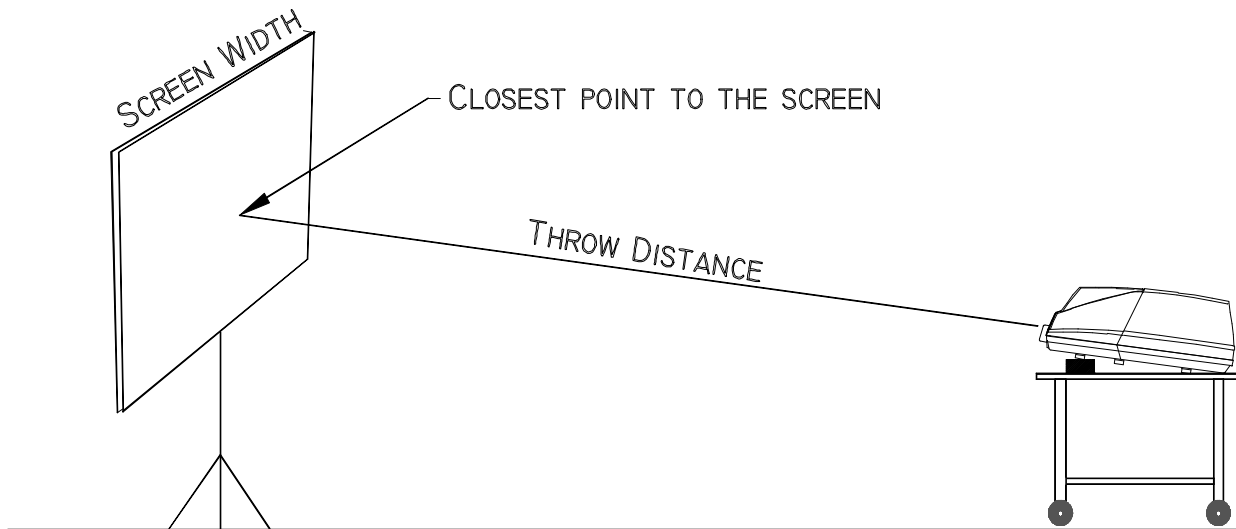

Figure 3-5. To find the Lens Throw Ratio, screen width or throw distance, use the formula:

$$\text{Lens Throw Ratio} = \frac{\text{Throw Distance}}{\text{Screen Width}}$$

When calculating the Lens Throw Ratio, if the result falls between two effective lens throw ratios in Table 3-3 or 3-4, drop down to the *next lower* Lens Throw Ratio to determine the proper lens set needed. (e.g. If the result shows a lens throw ratio of 6:1, drop down to a 5:1 lens. **Do not** go up to a higher lens throw ratio or the screen width desired may not be possible.

NOTE: When using the above formula to calculate throw distance: to account for measurement inaccuracies and manufacturing tolerances, the throw distance should be at least 2% longer than the throw distance calculated from the screen width and lens throw ratio.

Table 3-3. Lens Matrix for Projector Models 315, 320, and 335.

EFFECTIVE LENS THROW RATIO	BASE LENS	CONVERTER	COMMENTS
.885:1	.885:1	None Available	For screen widths 8.0'-13.33' lens set p/n 103280*
	.885:1	None Available	For screen widths 13.33'-20' lens set p/n 102692*
1.2:1	1.5:1	.8 Converter. p/n 102834.	Red/Green lens p/n 101241. Blue lens p/n 101715
1.5:	1.5:1	None	Red/Green lens p/n 101241. Blue lens p/n 101715.
2.177:1	2.177:1	None	Red lens p/n 102147 Green lens p/n 102148 Blue lens p/n 102149
2.4:1	3:1	.8 Converter p/n 102686	lens set p/n 900609* Bezel** p/n 101594.
3:1	3:1	None	lens set p/n 900609* Bezel** p/n 101594.
4:1	5:1	.8 Converter. p/n 102687.	lens set p/n 101239.
5:1	5:1	None	lens set p/n 101239.
7:1	7:1	None	lens set p/n 101240
10:1	10:1	None	lens set p/n 103342.

*When ordering a single **.885:1** lens or **3:1** lens, always specify the color the lens will be used with.

The **3:1 lens has a smaller diameter and requires a bezel that fits over the end of the lens to help keep random light from exiting the projector and disturbing the screen.

NOTE: The **.885:1**, **2.177:1** and **10:1** lenses are special orders items. Additional time must be allowed when ordering these lenses.

Table 3-4. Lens Matrix for Model 310E.

EFFECTIVE LENS THROW RATIO	BASE LENS	CONVERTER	COMMENTS
1.1:1	.885:1	None	For screen widths 8.0'-13.33' lens set p/n 103280*.
	.885:1	None	For screen widths 13.33'-20' lens set p/n 102692*.
1.5:1	1.5:1	.8 Converter. p/n 102834.	Red/Green lens p/n 101241. Blue lens p/n 101715
1.875:	1.5:1	None	Red/Green lens p/n 101241. Blue lens p/n 101715.
2.72:1	2.177:1	None	Red lens p/n 102147 Green lens p/n 102148 Blue lens p/n 102149
3:1	3:1	.8 Converter p/n 102686	lens set p/n 900609* Bezel** p/n 101594.
3.75:1	3:1	None	lens set p/n 900609* Bezel** p/n 101594.
5:1	5:1	.8 Converter. p/n 102687.	lens set p/n 101239.
6.25:1	5:1	None	lens set p/n 101239.
8.75:1	7:1	None	lens set p/n 101240
12.5:1	10:1	None	lens set p/n 103342.

*When ordering a single **.885:1** lens or **3:1** lens, be sure to specify the color the lens will be used with.

The **3:1 lens has a smaller diameter and requires a bezel that fits over the end of the lens to help keep random light from exiting the projector and disturbing the screen.

NOTE: The **.885:1**, **2.177:1** and **10:1** lenses are special orders items. Additional time must be allowed when ordering these lenses.

Figure 3-6. Lens Chart for Model 315, 320 and 335.

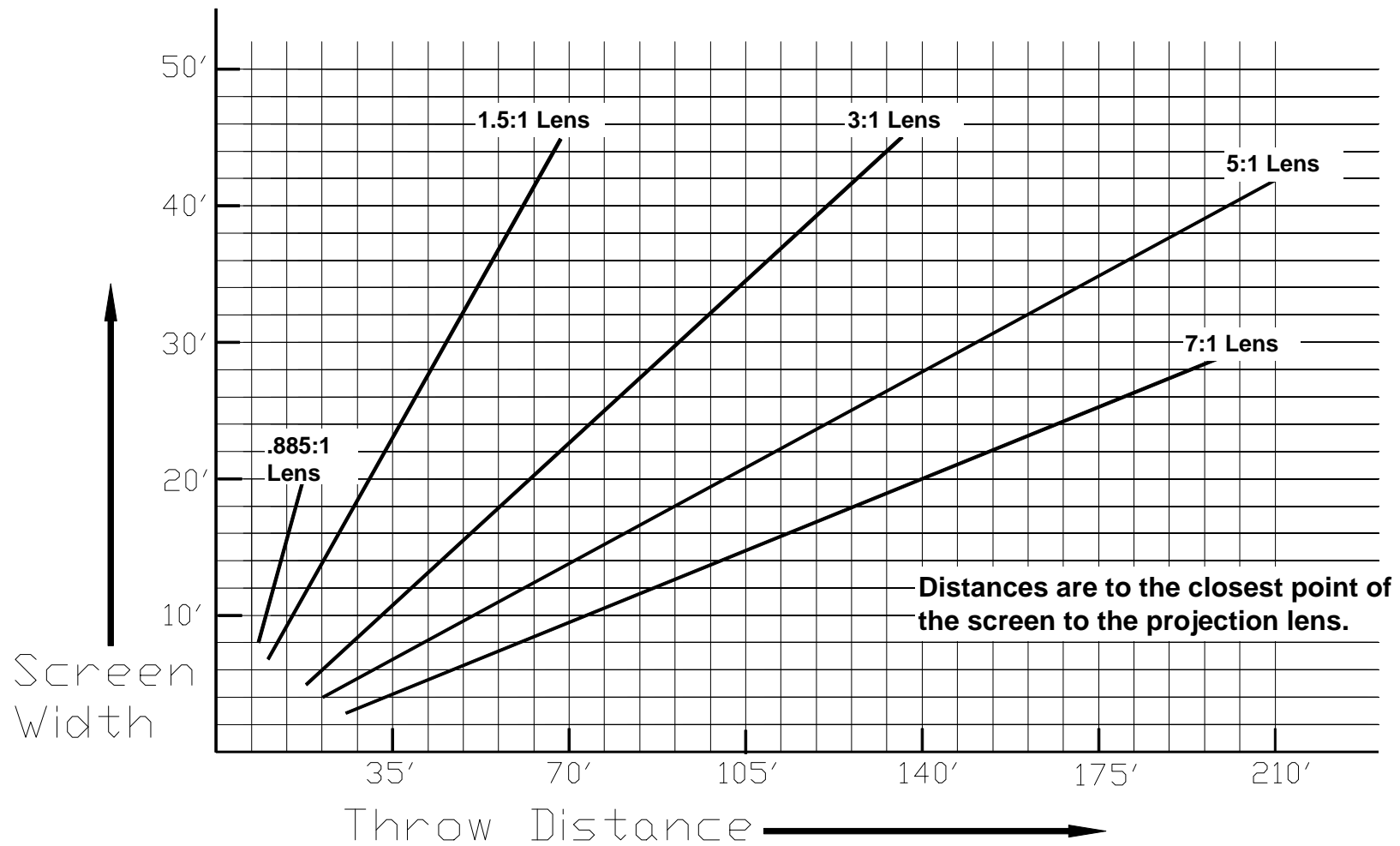

To use this graph, locate your throw distance (lens to closest point on the screen) and screen width. Move to the closest lens line **to the left** of that point to find the best lens for that application.

Figure 3-7. Lens Chart for Model 310.

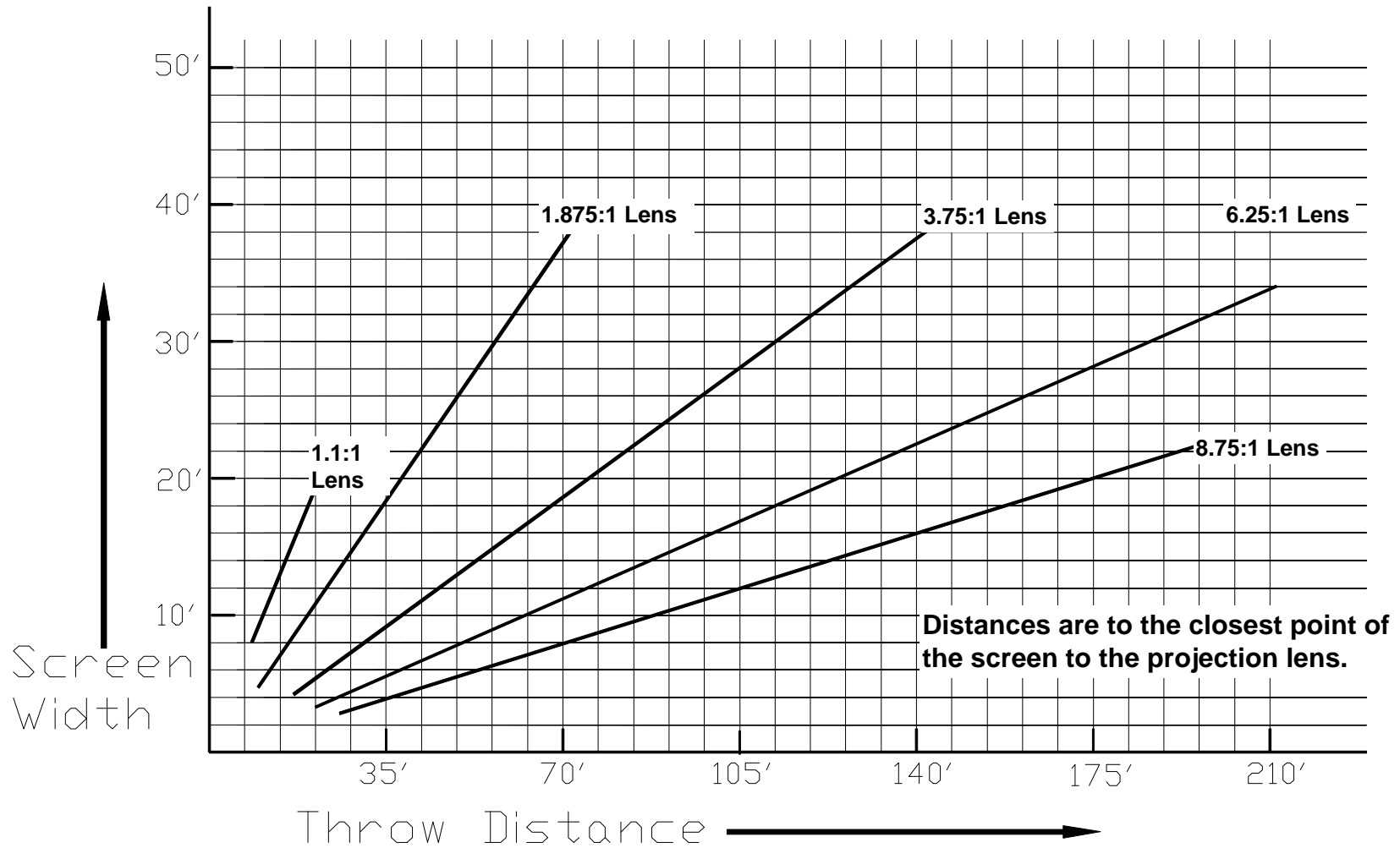

To use this graph, locate your throw distance (lens to closest point on the screen) and screen width. Move to the closest lens line **to the left** of that point to find the best lens for that application.

3.5 System Connections

This section reviews the connections and controls for operation of the Series 300 Projector.

CAUTION!!!

Before you begin, it is important that you read, understand and strictly adhere to the safety issues outlined in the Safety Information section at the front of this manual.

All connectors are on the rear panel of the projector. Figure 3-8 shows the rear panel connections of the Series 300 Projector.

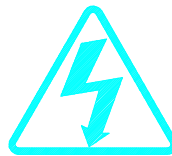

Risk of Electric Shock WARNING!!!

Use only the approved power connector that is supplied with the projector. **Do Not** hard wire a power cable in. This is in violation of NEMA codes. The receptacle must be in sight of the projector.

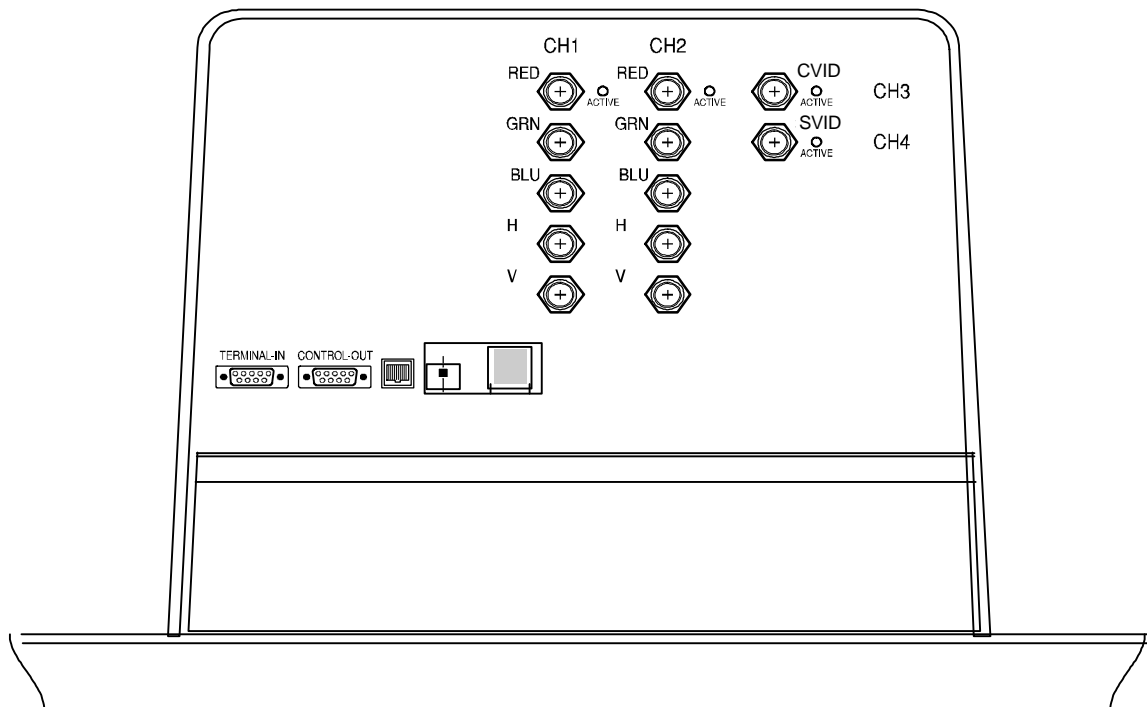

Figure 3-8. Series 300 Projector back panel connections.

Power Connections

The Series 300 Projector (Models 310E, 315, 320) operates from a 208-254V, 20A single-phase, 50-60 Hz AC power source and draws approximately 12 amps. Model 335 requires a 30A source and draws approximately 17 amps.

The Series 300 Projector operates from a 208V -254V, 20 Amp, single-phase, 50 - 60 Hz AC power source (Model 335 requires a 30 amp source). **MAKE SURE YOUR LOCAL POWER SOURCE MATCHES THESE REQUIREMENTS BEFORE OPERATION!**

Installation should be performed by an electrician with current knowledge of electrical codes in the country of use.

CAUTION! Before connecting more than one projector to the same power source, consider each projector's current draw as mentioned in the above paragraph. **Do not plug two projectors into one 20 amp source or a circuit overload will occur!**

There is a circuit breaker on the right side of the system power supply, under the back cover (*Figure 3-9*). An interlock switch prevents the projector from operating with the back cover removed unless the interlock switch is set properly. Neither of these switches is accessible during normal operation.



Figure 3-9. The main circuit breaker and interlock switch are on the right side of the system power supply.

Terminal or Tethered Remote

Connect the Tethered Technician Remote or a VT100 Control Terminal to the RS-232 control jack, (marked TERMINAL IN), on the projector back panel. The projector can also be controlled with the IR (InfraRed) Technician Remote, which is identical to the tethered technician remote, but without the LC Display and cable.

InfraRed Repeater

The InfraRed repeater is used with rear projection setups and in situations where the IR remote is a long distance, (50' or more) from the projector. With rear projection, the InfraRed windows are hidden by the screen from the remote control. The InfraRed repeater is plugged into the Series 300 Projector, (at the telephone-style connector on the rear panel), and placed in front of the screen, or any convenient location, where it receives the signal from the remote control and conveys it to the projector.

InfraRed (IR) Windows

The Series 300 Projector has two IR windows, one in front, one in back. These windows receive projector control signals from the IR remotes.

3.6 Video Sources

The Series 300 Projector accommodates a wide range of video formats, from standard single-cable composite video to a multitude of computer graphics standards and many other standard and custom formats. For any given installation, it is critical that the projector be compatible with all anticipated sources. The key parameters for projector compatibility are the signal standard, horizontal and vertical scan rates and blanking times, and video bandwidth.

Types of Standard Composite Signals

A composite signal carries vertical and horizontal synchronization information as well as luminance (brightness), chroma (color) and video information. There are a number of different standards for composite video, the more commonly known being NTSC (for US consumer television), PAL and SECAM (standards used overseas), and RS-170 (closed circuit monochrome). These standards differ in relation to parameters such as signal timing and the encoding scheme for the "video" information.

Red, Green and Blue Analog Signals

The most generalized computer graphics projector input is separate red, green and blue (RGB) analog signals. The sync signals for RGB analog sources can be separate horizontal and vertical, composite (horizontal and vertical combined) or included with the green analog signal (sync on green).

Signal Inputs

The Series 300 Projector allows the source(s) to be connected directly to the projector via appropriate connecting cables.

Signal input jacks are located on the rear panel of the projector. Their positions are illustrated in Figure 3-8, above.

The Series 300 Projector has the following input jacks:

2 RGB inputs, compatible with any of the following sync combinations:

- R, G, B, H, V
- R, G, B, H/V---**NOTE:** Connect composite sync (H/V) to the H input on the rear panel.
- R, Gs, B (sync on green)

1 Composite Video
1 S-Video Composite

Connect the source signal to the back panel. LEDs on the back panel light when you select a particular input.

3.7 Front/Rear or Inverted Vertical Projection

CAUTION: Access to the printed circuit boards for installing jumpers to either reverse the image horizontally or invert the image vertically require the removal of the projector cover. These procedures should be performed by Hughes Certified Technicians and Engineers only.

3.7.1 Front/Rear Jumper Setting(Horizontal Reverse)

The Horizontal Scan Reversal Jumper reverses the image projection for front or rear projection. Figure 3-10 illustrates the location of the jumpers on the Horizontal Deflection Board, (the board that is furthest from the rear of the projector-refer to Figure 2-7), and indicates the proper location for front and rear projection. The Series 300 Projector is shipped with the jumper plug inserted in J500 for front projection. For a rear projection setup, insert this jumper plug into J501.

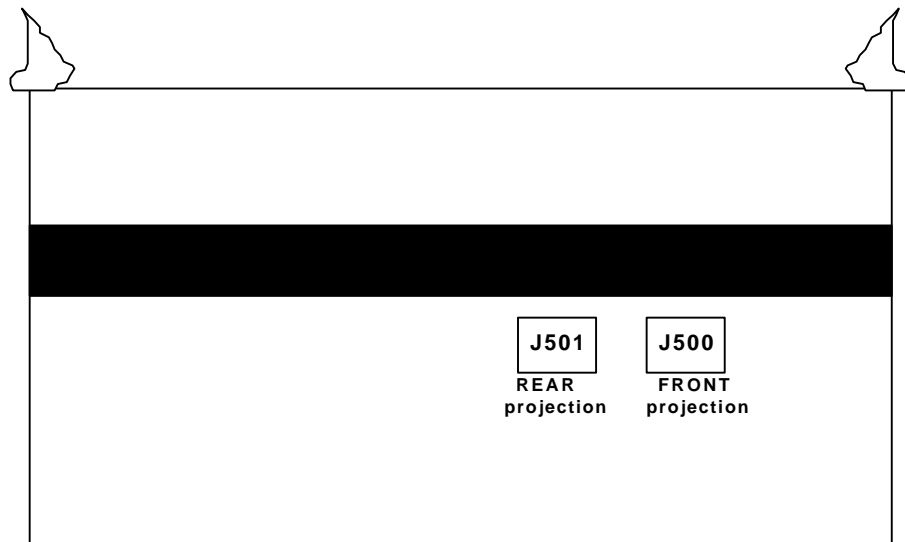

Figure 3-10. The Horizontal Scan jumper and jacks are located on the Horizontal Deflection board. The jumper is installed at the factory in J500 for front projection.

NOTE ON REPLACING THE HORIZONTAL DEFLECTION BOARD: The Horizontal Deflection Board (P/Ns 100566 & 102523) could be damaged if the board is not seated properly on the backplane. This problem usually occurs when the HDB is removed and reinserted after a board failure or when changing

the sweep reversal connector. A failure can occur if connector J11 on the HDB (located at the far right when viewing from the component side) does not connect completely with P11 on the backplane. To ensure a proper connection between J11 and P11 follow the procedure below:

- Before installing the Horizontal Deflection Board, remove the Vertical Deflection Board. This allows for a full inspection of the proper connection of J11 and P11. The P11 connector on the backplane is slightly loose to allow movement for minor dimensional differences in the position of the J11 connector on the HDB. Do not tighten connector P11 on the backplane.

To set the Horizontal Scan Jumper:

1. Turn power off at the projector and wait about three minutes for the arc lamp to cool.
2. Remove the rear cover from the projector.
3. Remove the cover from the card cage.
4. Pull out the Horizontal Deflection board and verify that the horizontal scan jumper is properly inserted for front (J500) or rear (J501) projection, depending on your application, (See *Figure 3-10*). Change jumper if necessary.
5. Replace the card cage cover.
6. Replace the rear projector cover.

3.7.2 Inverted Vertical Jumper Setting

The Vertical Invert jumpers invert the image vertically for use in some situations that use mirrors or ceiling projections. Figure 3-11 illustrates the location of the jumpers on the Vertical Deflection Board, (the fourth board from the rear of the projector), and indicates the proper location for normal vertical projection, (shaded boxes), and inverted vertical projection, (clear boxes). The Series 300 Projector is shipped in the normal vertical projection position with jumpers in J200, J300 and J400. For an inverted vertical setup change the jumpers to J201, J301 and J401. (Refer to *Figure 3-11*).

NOTE: The Series 300 Projector was designed to operate rightside up and at angles up to 85°, not inverted or at 90°!

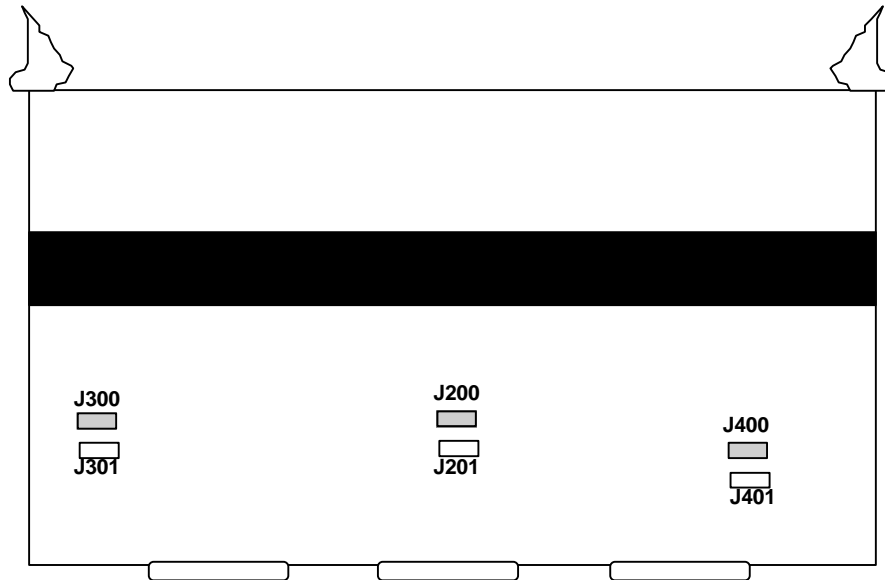

Figure 3-11. Vertical scan jumpers on the Vertical Deflection Board are factory installed into the shaded jacks for standard viewing.

To invert the vertical image:

1. Turn power off at the projector and wait about three minutes for the arc lamp to cool.
2. Remove the rear cover from the projector.
3. Remove the cover from the card cage.
4. Pull out the Vertical Deflection Board and verify that the vertical jumpers are inserted in the correct jacks, depending on your application, (see *Figure 3-11*). Change jumpers if necessary.
5. Replace the card cage cover and rear projector cover.

3.8 Connections Checklist

- Connect the power cord to a 208-254 VAC, 50/60 Hz, 20 amp source (30 amp for Model 335), single phase power source.

Caution!!!

If there is any visible damage to any of the cables do not apply power to the projector until the damaged cable is replaced.

- Connect the Tethered Tech Remote, (if using), VT-100 or PC, to the RS-232 Control jack, (marked TERMINAL IN) on the projector back panel.
- Connect the signal inputs to the jacks at the projector rear panel corresponding to the signals you are using. (*Figure 3-8*)

- If you are using rear panel projection, connect the jumper to J501, as shown in Section 3.7.1 and in Figure 3-10.
- If you are using an Extron switcher, connect it to the output marked CONTROL OUT. (*Figure 3-8*)
- If you are using an IR Repeater connect it to the telephone-style connector next to the CONTROL OUT jack. It is advisable to use the IR Repeater for distances of 50 feet or more from the projector to the IR remote. Bear in mind that IR distances are for **LINE OF SIGHT** only.

