

# 3.0 Installation Requirements

## Contents

3.1 Projector Dimensions .....	3-1
3.2 Projector Weight .....	3-3
3.3 Physical Access and Air Flow Clearance .....	3-3
3.4 Exhaust Air Venting.....	3-4
3.5 Electrical Requirements .....	3-5

## 3.1 Projector Dimensions

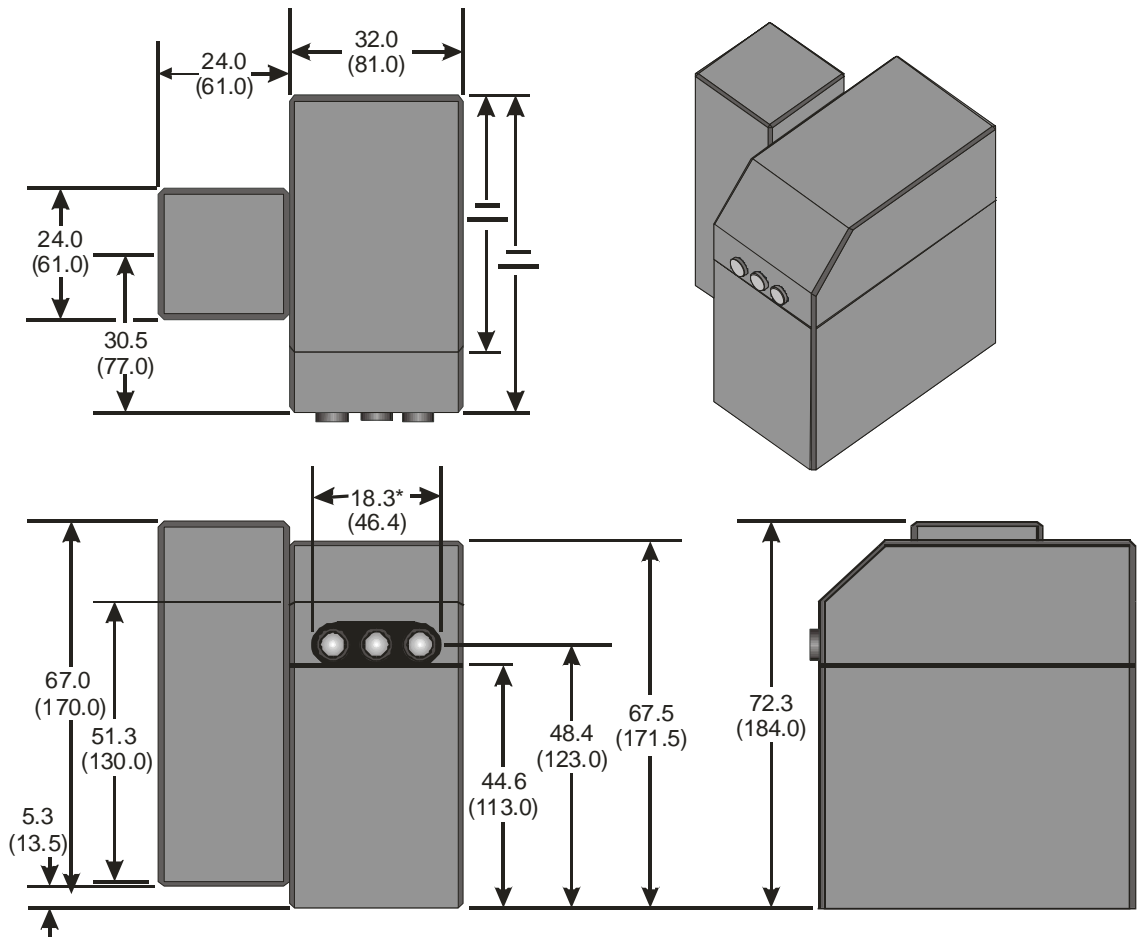

**Figure 3-1** Projector enclosure dimensions in inches (cm in parentheses).

\* Include a cone angle when calculating for a view port window (see Table 3-1).

## View Port Considerations

If the ILA-12K projector is going to be installed in an enclosure with a view port window that the light will travel through to the screen, it is important to have adequate clearance that takes into consideration the cone angle for the projection lens being used. Use Table 3-1 and Figure 3-2 to determine adequate view port clearance.

**Table 3-1** Cone Angle for view port window

Lens type	Cone Angle ( $\theta$ ) (in degrees)
0.855:1	29.5°
1.5:1 w/ 0.8 Converters	22.6°
1.5:1	18.4°
2.177:1	12.9°
3:1 w/ 0.8 Converters	11.8°
3:1	9.5°
5:1 w/ 0.8 Converters	7.1°
5:1	5.7°
7:1 w/ 0.8 Converters	5.1°
7:1	4.1°
10:1	2.9°

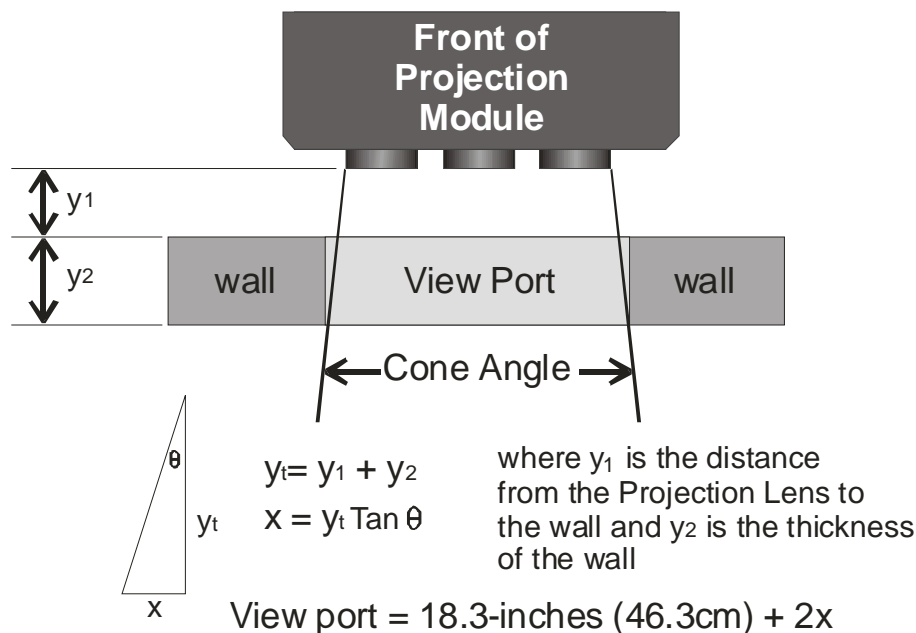

**Figure 3-2** Top view of front section of the Projection Module showing cone angle of light output.

### 3.2 Projector Weight

It is important to consider the weight of the projector in planning for the final location. Ensure the projector is installed in a location that will provide adequate structural support.

**Table 3-2** Projector weight

Component	Weight (US)	Weight (Europe)
Projection Module	1472 pounds	668 kg
Arc Lamp Module	193 pounds	87 kg
Total	1665 pounds	755 kg

### 3.3 Physical Access and Air Flow Clearance

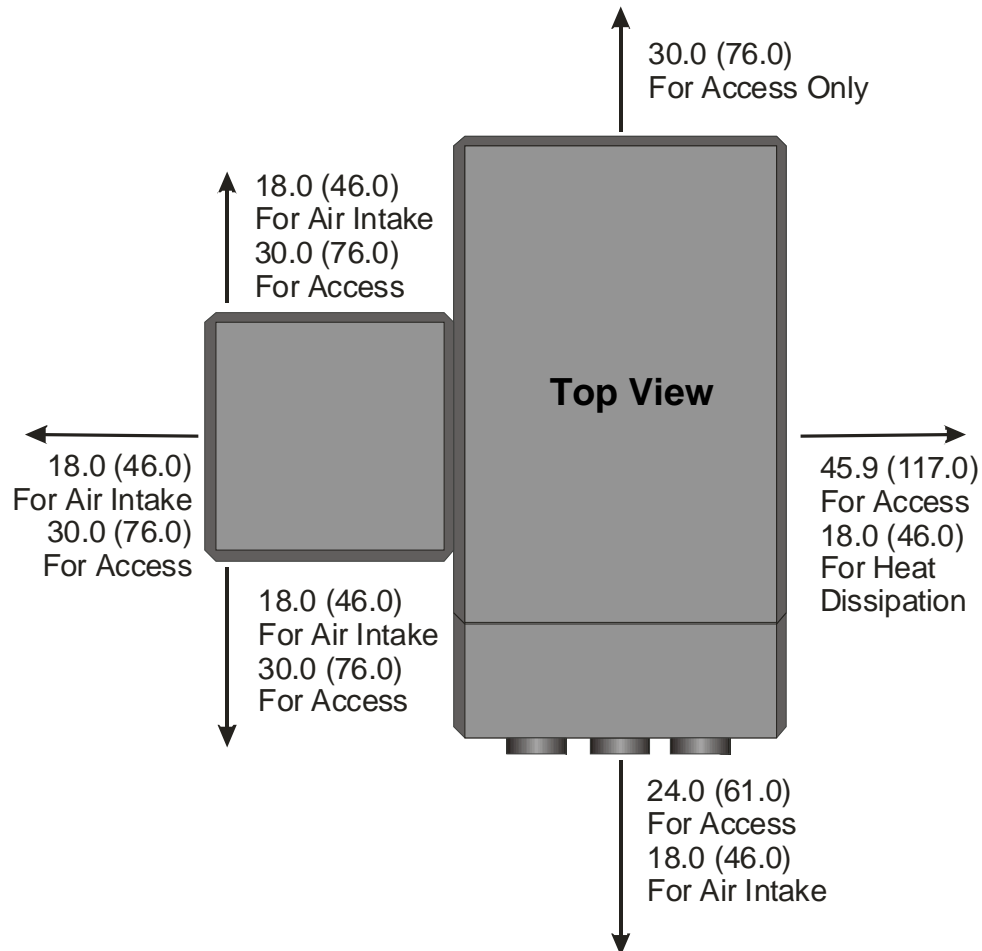
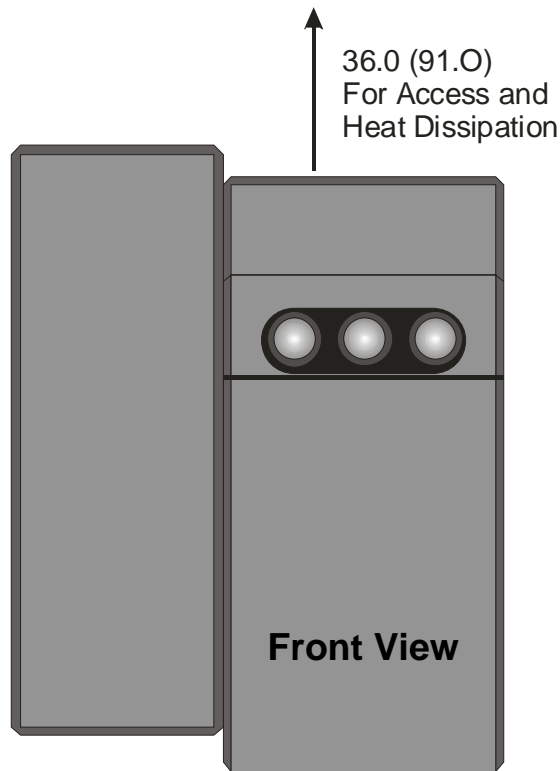

**Figure 3-3** Clearances for physical access and air flow at *sides* of projector in inches (cm in parentheses).

**NOTE:** Clearances for airflow are a minimum for rooms of normal ambient air temperature. Rooms with hot ambient air temperature may require greater clearance to dissipate heat properly.



**CAUTION!** The projector dissipates 40,978 btus/hr (12,000 kW/h) and requires adequate ventilation for proper airflow to prevent overheating. **Do not** place the projector in an enclosure that would limit airflow.

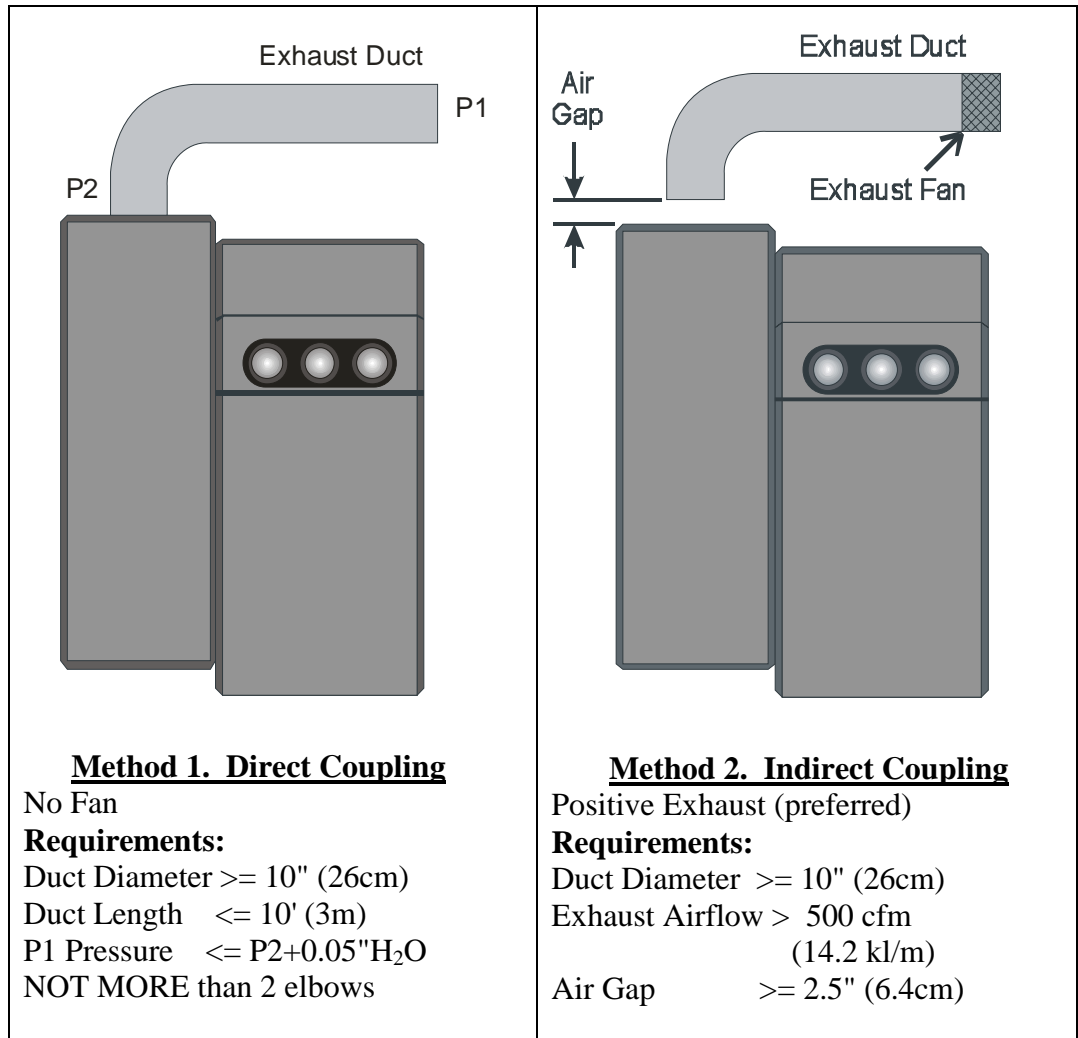

**Figure 3-4** Clearances for air flow on top of projector in inches (cm in parenthesis).

### 3.4 Exhaust Air Venting

The Arc Lamp Module exhaust air should be exhausted outside the room to reduce the air conditioning heat load by about 13,000 BTUs (3.81 kW/h). If exhausted separately the clearances above the projector, shown in Figure 3-4, can be reduced to 24"(61cm).

Ducting of the Arc Lamp Module exhaust air should be performed according to one of the two methods, shown in Figure 3-5, below. Method 2 is preferred because variations in the air flow rate and pressures will have minimum impact on the Model ILA-12K cooling operation.



**Figure 3-5** Recommended ventilation for projector exhaust air.

### 3.5 Electrical Requirements

The projector operates from a 3-phase, 5-wire-WYE (4 wire-DELTA in Japan) source. Voltages, currents, and line frequencies vary with the country of use (see below)

**Table 3-3** Electrical configuration for different countries

Countries	Voltage	Current	Line Frequency
United States	208 VAC	60 Amps	60 Hz
Japan	200 VAC	60 Amps	50-60 Hz
European	380/400/416 VAC	32 Amps	50 Hz

**NOTE:** Verify that local power source matches these requirements before operation!

## AC Power Configuration

The following diagram illustrates the different AC Power configurations for different countries:

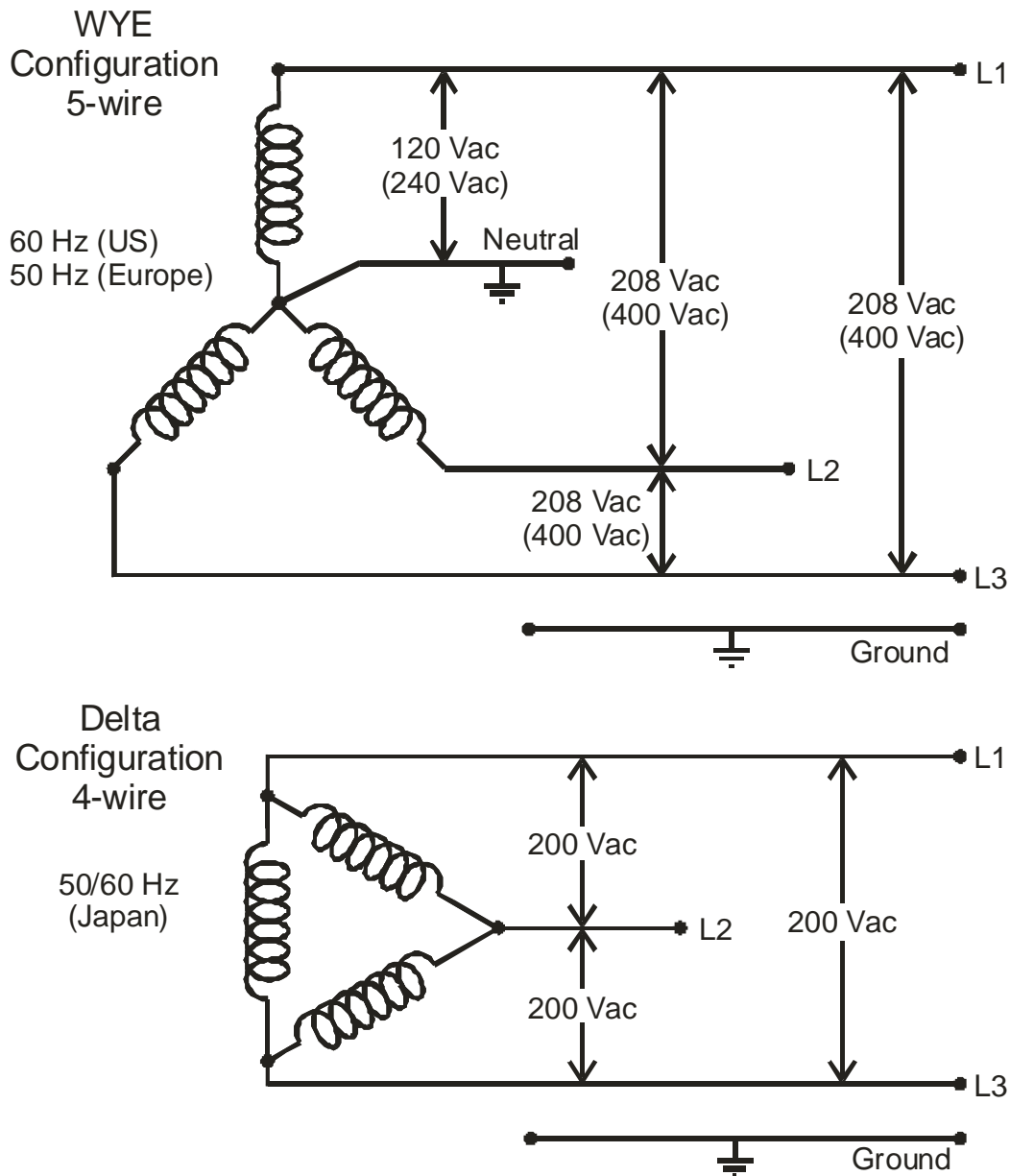

**Figure 3-6** AC Power configurations for different countries.

## AC Power Connector

The projector's power plug was designed for a three phase, five wire source. The power plug shipped with the projector may have to be changed to meet electrical codes for local authorities. It is the user's responsibility to contact an electrician, familiar with the current electrical codes in the country of use, for proper wiring.

The AC Power connections require the following parts:

**Figure 3-7** Electrical components for different countries

Electrical component	US/Japan	European
AC Power plug*	Hubbel 560P9W	Hubbel 523P6W
AC Power connector	Hubbel 560C9W	Hubbel 523C6W
AC Power receptacle	Hubbel 560R9W	Hubbel 523R6W

\*supplied with projector

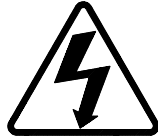

**WARNING!!!** JVC Digital IMAGE Technology Center is not responsible for any hazards caused by unlicensed personnel altering the original three phase, five wire Hubbel AC Power connector.

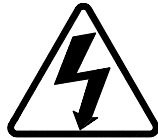

**WARNING!!!** To prevent electrical shock, disconnect AC Power at the main breaker before removing any projector panels to perform service.



**WARNING!!!** If there is any visible damage to the AC Power Cable, disconnect AC Power to the projector at the source until the damaged cable is replaced.