

D-ILA[®]
Home Theater Projector
DLA – HD10K Series

RS-232C CONTROL SPECIFICATIONS

Ver 1.2

Victor Company of Japan, Limited

* D-ILA is a trademark of Victor Company of Japan, Limited.

Document Number CTGKE-0031

CONTENTS

1. OUTLINE	3
2. COMMUNICATION FORMAT	3
3. DATA FORMAT	3
3.1 Command Data Format (External Control to Projector).....	3
3.2 Tally (Response) Data Format (Projector to External Control).....	3
3.2.1 Tally (Response) Data when Terminated Normally.....	3
3.2.2 Tally Data when Error Occurs.....	4
3.3 Internal Error Data Format (Projector to External Control).....	4
4. HEADER	5
4.1 External Control to Projector.....	5
4.2 Projector to External Control.....	5
5. ID	5
6. CR	6
7. PARAMETERS	6
7.1 Numeric Value Parameter.....	6
7.2 ON/OFF Status Parameter.....	6
7.3 Special Parameters.....	7
7.3.1 Back Color Parameter.....	7
7.3.2 Color Temperature Parameter.....	7
7.3.3 Menu Display Auto OFF Parameter.....	7
7.3.4 Zoom/Focus Parameter.....	7
7.3.5 Transfer Rate Parameter.....	7
7.3.6 ID Parameter.....	7
7.3.7 Gamma Table Parameter.....	8
7.3.8 Mask Parameter.....	8
7.3.9 Test Pattern Parameter.....	8
7.3.10 Zoom/Focus Lock Parameter.....	9
7.3.11 Projector Operation Mode Parameter.....	9
7.3.12 Horizontal Pixel Adjust Parameter.....	9
7.3.13 Vertical Pixel Adjust Parameter.....	10
8. TALLY(RESPONSE)DATA	11
8.1 Tally (Response) Data Status.....	11
8.1.1 Normal Termination Status.....	11
8.1.2 Status when Error Occurs (Error Status).....	11
8.2 Tally (Response) Data Parameter.....	11
9. INTERNAL ERRORS	12
9.1 Internal Error Data Status (Internal Error Status).....	12
9.2 Internal Error Data Parameters.....	12
9.3 Internal Error Data Reply Timing.....	13
10. PROJECTOR OPERATION MODES	14
10.1 Standby Mode.....	14
10.2 Power ON Mode.....	14
10.3 Cool-Down Mode.....	14
10.4 Emergency Mode.....	14
11. SOURCE	15
11.1 Sources and Source Numbers.....	15
12. COMMANDS	16
12.1 HIDE.....	:‘U00’(55H 30H 30H).....17
12.2 Back Color.....	:‘U01’(55H 30H 31H).....18
12.3 Color Temperature Table.....	:‘U0B’(55H 30H 42H).....19
12.4 Color Temperature(RED).....	:‘U0C’(55H 30H 43H).....20

12.5	Color Temperature(GREEN)	:‘U0D’(55H 30H 44H)	21
12.6	Color Temperature(BLUE)	:‘U0E’(55H 30H 45H)	22
12.7	POWER	:‘U0F’(55H 30H 46H)	23
12.8	MENU Auto OFF	:‘U10’(55H 31H 30H)	24
12.9	Sleep Time	:‘U12’(55H 31H 32H)	25
12.10	Zoom W	:‘U13’(55H 31H 33H)	26
12.11	Zoom T	:‘U14’(55H 31H 34H)	27
12.12	Focus +	:‘U15’(55H 31H 35H)	28
12.13	Focus -	:‘U16’(55H 31H 36H)	29
12.14	Right/Left Reverse	:‘U17’(55H 31H 37H)	30
12.15	Top/Bottom Invert	:‘U18’(55H 31H 38H)	31
12.16	Transfer Rate	:‘U1B’(55H 31H 42H)	32
12.17	Lamp Time	:‘U1C’(55H 31H 43H)	33
12.18	ID	:‘U1D’(55H 31H 44H)	35
12.19	Gamma Table	:‘U73’(55H 37H 33H)	36
12.20	Mask	:‘UA0’(55H 41H 30H)	37
12.21	Test Pattern	:‘UA1’(55H 41H 31H)	38
12.22	Picture Shift	:‘UA2’(55H 41H 32H)	39
12.23	Zoom/Focus Lock	:‘UA9’(55H 41H 39H)	40
12.24	Power Save	:‘UAA’(55H 41H 41H)	41
12.25	Horizontal Pixel Adjust (RED)	:‘UB0’(55H 42H 30H)	42
12.26	Horizontal Pixel Adjust (GREEN)	:‘UB1’(55H 42H 31H)	43
12.27	Horizontal Pixel Adjust (BLUE)	:‘UB2’(55H 42H 32H)	44
12.28	Vertical Pixel Adjust (RED)	:‘UB3’(55H 42H 33H)	45
12.29	Vertical Pixel Adjust (GREEN)	:‘UB4’(55H 42H 34H)	46
12.30	Vertical Pixel Adjust (BLUE)	:‘UB5’(55H 42H 35H)	47
12.31	Operation Mode Query	:‘Z03’(5AH 30H 33H)	48
12.32	Source Query	:‘Z05’(5AH 30H 35H)	49
12.33	Projection Model Query	:‘Z0A’(5AH 30H 41H)	50

13. APPENDIX	51
13. 1	External Control Command List.....	51
13. 2	RS-232C Port Pin Configuration	53
13. 3	Flow chart of “Power ON Control”	54
13. 4	Flow chart of “Power OFF Control”	55
13. 5	Revision History	56

1. OUTLINE

This document describes the communication and data formats used to control the projector via its RS-232C port.

2. COMMUNICATION FORMAT

Transfer Rate : 9600, 19200(default) bps
Data Length : 8 bits
Parity Bit : None
Stop Bit : 1 bit
Flow Control : None

3. DATA FORMAT

3.1 Command Data Format (External Control to Projector)

Header ID SP Command SP Parameter SP Parameter SP . . CR

Header : Indicates the beginning of data and data type
'!' (21H) : Command for the Projector
'?' (3FH) : Query to the Projector (Request for data)

ID : Identification number of Projector

SP : Indicates the separation between ID and command, command and parameter, parameter and parameter (20H)

CR : Indicates the end of data (0DH)

3.2 Tally (Response) Data Format (Projector to External Control)

3.2.1 Tally (Response) Data when Terminated Normally

Header ID SP Normal Termination Status SP Parameter SP Parameter . . CR

Header : Indicates the beginning of tally (response) data
'@' (40H)

ID : Identification number of the Projector

SP : Indicates the separation between ID and status, status and parameter, parameter and parameter (20H)

Normal Termination Status : '0' (30H)

CR : Indicates the end of data (0DH)

* Parameter is sent when tally (response) data is issued in response to a query (request for data.) There is no parameter for tally (response) data in response to a command.

3.2.2 Tally Data when Error Occurs

Header ID SP Error Status CR

Header : Indicates the beginning of the tally (response) data
'@'(40H)

ID : Identification number of Projector

SP : Indicates the separation between ID and Status(20H)

Error Status : 'A00' (41H 30H 30H)
'A01' (41H 30H 31H)
'A02' (41H 30H 32H)
'A03' (41H 30H 33H)
'A04' (41H 30H 34H)
'A05' (41H 30H 35H)
'A0A' (41H 30H 41H)
'A0B' (41H 30H 42H)

CR : Indicates the end of the data(0DH)

*For details on error status, refer to 8. Tally (Response) Data.

3.3 Internal Error Data Format (Projector to External Control)

Header ID SP Internal Error Status SP Parameter SP Parameter SP · · CR

Header : Indicates the beginning of the internal error data
'&(26H)

ID : Identification of Projector

SP : Indicates the separation between ID and status, status and parameter, parameter
and parameter(20H)

Internal Error Status : 'E01' (45H 30H 31H)
'E06' (45H 30H 36H)
'E07' (45H 30H 37H)
'E08' (45H 30H 38H)
'E09' (45H 30H 39H)
'E15' (45H 31H 35H)

CR : Indicates the end of the data(0DH)

* For details on internal error status, refer to 9. Internal Errors.

4. HEADER

Indicates the beginning and type of communication data.

4.1 External Control to Projector

Character	HEX	Definition
'!	21	Command to the Projector
'?	3F	Query (request for information) to the Projector

4.2 Projector to External Control

Character	HEX	Definition
'@'	40	Tally (Response) data
'&'	26	Internal error data

5. ID

Numeric characters are used to identify an individual Projector when two or more Projector units are connected to a single control machine.

Setting separate identification numbers for each Projector allows independent control of each Projector unit.

Assignable ID numbers

'0' (30H)	'8' (38H)
'1' (31H)	'9' (39H)
'2' (32H)	'A' (41H)
'3' (33H)	'B' (42H)
'4' (34H)	'C' (43H)
'5' (35H)	'D' (44H)
'6' (36H)	'E' (45H)
'7' (37H)	'F' (46H)

* Factory set ID is '1' (31H).

ID number '0' (30H) should be used when assigning all connected Projector units for batch operations. This means that when assigning independent ID numbers to multiple units, 15 of the 16 assignable numbers (from '1' through 'F') can actually be used for registration.

Please note that tally (response) data is not returned from the projector when the global ID assignment function (0) is used.

6. CR

Indicates the end of each set of data. (0DH)

7. PARAMETERS

There are three types of parameters:

1. Indicates the numeric value.
2. Indicates the ON/OFF status.
3. Special parameter.

7.1 *Numeric Value Parameter*

Signed 2-byte hexadecimal code represented by 4 (byte) characters.
Assignable range is between '8000' and '7FFF'.

Ex-1) The parameter indicating '20' (decimal):
Since '20' (decimal) is represented as '0014' in signed 2-byte hexadecimal,
its parameter is:

'0014'(30H 30H 31H 34H)

Ex-2) The parameter to indicate '-2' (decimal):
Since '-2' (decimal) is represented as 'FFFE' in signed 2-byte hexadecimal, its parameter is:

'FFFE'(46H 46H 46H 45H)

7.2 *ON/OFF Status Parameter*

Indicates the ON/OFF status of items such as POWER or HIDE.

Character	HEX	Definition
'0'	30	OFF
'1'	31	ON

7.3 Special Parameters

Parameters other than those described in 7.1 to 7.2.

7.3.1 Back Color Parameter

Character	HEX	Definition
'0'	30	Blue
'1'	31	Black

7.3.2 Color Temperature Parameter

Character	HEX	Definition
'0'	30	D65
'2'	32	USER1
'3'	33	USER2

7.3.3 Menu Display Auto OFF Parameter

Character	HEX	Definition
'0'	30	15sec
'1'	31	ON

7.3.4 Zoom/Focus Parameter

Character	HEX	Definition
'0'	30	STOP
'1'	31	START

7.3.5 Transfer Rate Parameter

Character	HEX	Definition
'0'	30	9600bps
'1'	31	19200bps

7.3.6 ID Parameter

Character	HEX	Definition
'0'	30	ID 0(global command for all projectors)
'1'	31	ID 1
'2'	32	ID 2
'3'	33	ID 3

'4'	34	ID 4
'5'	35	ID 5
'6'	36	ID 6
'7'	37	ID 7
'8'	38	ID 8
'9'	39	ID 9
'A'	41	ID 10
'B'	42	ID 11
'C'	43	ID 12
'D'	44	ID 13
'E'	45	ID 14
'F'	46	ID 15

7.3.7 Gamma Table Parameter

Character	HEX	Definition
'0'	30	NORMAL
'1'	31	A
'2'	32	B
'3'	33	CUSTOM

7.3.8 Mask Parameter

Character	HEX	Definition
'0'	30	0%
'1'	31	2.5%
'2'	32	5%

7.3.9 Test Pattern Parameter

Character	HEX	Definition
'0'	30	OFF
'1'	31	Color Bar
'2'	32	Ramp(Black and White)
'3'	33	Ramp(only R)

'4'	34	Ramp(only G)
'5'	35	Ramp(only B)
'6'	36	Stair Case(Black and White)
'7'	37	Stair Case(only R)
'8'	38	Stair Case(only G)
'9'	39	Stair Case(only B)
'A'	41	Cross Hatch(only G)

7.3.10 Zoom/Focus Lock Parameter

Character	HEX	Definition
'0'	30	Unlock
'1'	31	Lock

7.3.11 Projector Operation Mode Parameter

Character	HEX	Definition
'000'	30H 30H 30H 30H	Standby Mode
'001'	30H 30H 30H 31H	Power ON Mode
'002'	30H 30H 30H 32H	Cool-Down Mode
'004'	30H 30H 30H 34H	Emergency Mode

7.3.12 Horizontal Pixel Adjust Parameter

Character	HEX	Definition
'1'	31	Pixel moves left by three pixels
'2'	32	Pixel moves left by two pixels
'3'	33	Pixel moves left by one pixel
'4'	34	Pixel moves to standard position
'5'	35	Pixel moves right by one pixel
'6'	36	Pixel moves right by two pixels
'7'	37	Pixel moves right by three pixels

7.3.13 Vertical Pixel Adjust Parameter

Character	HEX	Definition
'1'	31	Pixel moves below by three pixels
'2'	32	Pixel moves below by two pixels
'3'	33	Pixel moves below by one pixel
'4'	34	Pixel moves to standard position
'5'	35	Pixel moves above by one pixel
'6'	36	Pixel moves above by two pixels
'7'	37	Pixel moves above by three pixels

8. TALLY(RESPONSE)DATA

The Projector will only accept and process data when the ID number included with the data coincides with the ID-number registered to the Projector itself. (Except when ID = '0') If the received ID-number matches the Projector's ID, it will return a response to the query from the external control unit. This response data is called "Tally (Response) Data". (However, when ID = '0', tally (response) data is not replied.)

The Tally (Response) Data is normally returned within 3 seconds after the data is received. There are some exceptions, however (e.g. POWER command)

After transmitting data, the external control unit cannot transmit subsequent data until the Tally (Response) Data is received. However, if Tally (Response) Data is not returned within 3 seconds after transmitting the data (there are some exceptions such as the POWER command), data transmission can be retried.

8.1 Tally (Response) Data Status

8.1.1 Normal Termination Status

Character	HEX	Definition
'0'	30	Command received and processing terminated

8.1.2 Status when Error Occurs (Error Status)

Character	HEX	Definition
'A00'	41H 30H 30H	Command not supported
'A01'	41H 30H 31H	Invalid parameter
'A02'	41H 30H 32H	Parameter value exceeds operation range
'A03'	41H 30H 33H	Unclassified error
'A04'	41H 30H 34H	Unacceptable command in current mode or Unacceptable command with current setting
'A05'	41H 30H 35H	Command cannot be accepted if no signal.
'A0A'	41H 30H 41H	Time-out occurred with the communication with sub microcomputer
'A0B'	41H 30H 42H	Error occurred with the communication with sub microcomputer

8.2 Tally (Response) Data Parameter

The Tally (Response) Data Parameter is returned when the Tally (Response) Data is issued in response to a query (request for data). No parameter is returned when Tally (Response) Data issued in response to a command or when an error occurs.

9. INTERNAL ERRORS

Error data is returned to the external control unit when an error has occurred.

9.1 Internal Error Data Status (Internal Error Status)

Character	HEX	Definition
'E01'	45H 30H 31H	Lamp did not light
'E02'	45H 30H 32H	Lamp life time exceeded 2000 hours.
'E06'	45H 30H 36H	Lamp suddenly goes out (Lamp Shut Down) while projecting (in Power ON mode)
'E07'	45H 30H 37H	Fan is locked
'E08'	45H 30H 38H	Internal temperature is too high.
'E09'	45H 30H 39H	Temperature around air intake is going up abnormally.
'E15'	45H 31H 35H	Lamp cover is off.

9.2 Internal Error Data Parameters

There are two parameters for Internal Error Data.

Header ID SP Internal Error Status SP **Parameter 1** SP **Parameter 2** CR

Each parameter shows the slave address (Parameter 1) and Sub-Address (Parameter 2) when an IIC ACK error (Error status: 'E03') occurs.

The parameter type is "numeric value".

* Two parameters are also returned when an internal errors other than IIC ACK errors occur. In this case, however, the parameter's numeric value has no meaning.

Ex) Internal error data when IIC ACK error occurs with Slave address 'A0H' and Sub-address of '1F20H':

'&' ID SP 'E03' SP '00A0' SP '1F20' CR

9.3 Internal Error Data Reply Timing

When returning data, the Projector checks for internal error data. If such data exists, the internal error data is returned before the tally (response) data is transmitted. That is, if an internal error occurs, the Projector retains the internal error data, returning it in order of precedence a request for tally (response) data is received. Once transmitted, internal error data is deleted from the Projector.

10. PROJECTOR OPERATION MODES

This section describes the Projector's four basic operation modes.

10.1 Standby Mode

The Projector enters this mode when it is plugged into an AC outlet. The lamp does not light and the fans do not operate.

10.2 Power ON Mode

This mode is engaged when the POWER ON command is received and processed normally in the Standby mode. The lamp is lighted and the fans start rotating. Images can be projected in this mode.

10.3 Cool-Down Mode

This mode is engaged when the POWER OFF command is received and processed normally in the Power ON mode.

The lamp goes out and the fans are rotated continuously to cool down the lamp.

To avoid the lamp is lighted again in short time, the POWER ON command is not accepted during this mode.

The DLA-HD10K Series, the Cool-Down Mode time is approximate 60 seconds. The lamp goes out and the fans are rotated continuously during this mode to cool down the lamp.

After the mentioned time lapse, the unit automatically enters the Standby mode.

10.4 Emergency Mode

This mode is engaged when the projector malfunctions or is improperly operated.

The lamp and the fans are shut down and the AC outlet is unplugged.

Non-operation status continues until the reset function is activated.

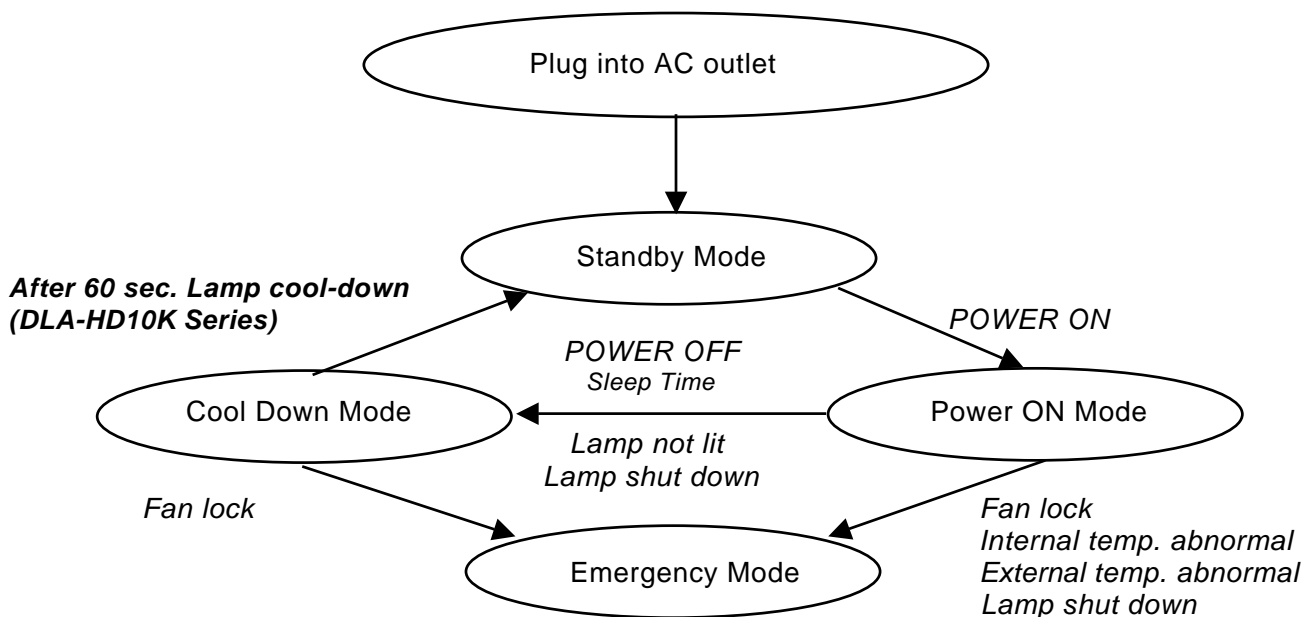

* Note that the acceptance/non-acceptance condition of a command differs depending on the operation mode.

11. SOURCE

The input signals to projectors can be only Video Sources of three kinds as follows.

- ◇ 1080p60
- ◇ 1080p50
- ◇ 1080p48

11.1 Sources and Source Numbers

Source	Source No. (Character)	Source No. (HEX)
1080p60	'10'	31H 30H
1080p50	'11'	31H 31H
1080p48	'12'	31H 32H
Out Of Range	'FE'	46H 45H
No Signal	'FF'	46H 46H

12. COMMANDS

This section describes the commands that can be used with the Projector.

- ◇ In the Communication Examples, the ID number registered on the Projector is represented as '1' (31H). This is the default setting.
- ◇ "CTRL" refers to transmissions from the external control unit and "DLA" refers to transmissions (Tally (Response) Data) from the Projector.
- ◇ "Reply Time" refers to the maximum time required between command reception and return of Tally (Response) Data. In other words, it refers to the maximum time that the external control unit must wait for the Tally (Response) Data.
- ◇ For details on the different parameters, refer to 7. Parameters.
- ◇ Acceptance or non-acceptance of a command in each operation mode is indicated by "O" (accept) or "X" (does not accept).

12.1 HIDE

: 'U00'(55H 30H 30H)

Definition : Controls video signal muting
Command : 'U00'(55H 30H 30H)
Parameter type : ON/OFF
Reply time : 3seconds
Conditions : This command is unavailable for about 5 seconds after turn on.
(At this time, error does not occur.)

Operation mode

Standby mode	Power ON mode	Cool-down mode	Emergency mode
X	O	X	X

Communication Examples

◇ To turn HIDE ON

```
CTLR  '!' '1' SP 'U00' SP '1' CR
DLA    '@' '1' SP '0' CR
```

◇ When requesting current HIDE status (if HIDE status is ON)

```
CTLR  '?' '1' SP 'U00' CR
DLA    '@' '1' SP '0' SP '1' CR
```

◇ When trying to change HIDE status in emergency mode (turn ON)

```
CTLR  '!' '1' SP 'U00' SP '1' CR
DLA    '@' '1' SP 'A04' CR
```

12.2 Back Color

: 'U01'(55H 30H 31H)

Definition : Controls back color

Command : 'U01'(55H 30H 31H)

Parameter type : Special parameter(Refer to 7.3.1 Back Color Parameter.)

Reply time : 3seconds

Conditions :

Operation mode

Standby mode	Power ON mode	Cool-down mode	Emergency mode
X	O	X	X

Communication Examples

- ◇ When specifying the back color to "black"

```
CTLR  '!' '1' SP 'U01' SP '1' CR
DLA    '@' '1' SP '0' CR
```

- ◇ When requesting the current back color data(if the back color is set to "blue")

```
CTLR  '?' '1' SP 'U01' CR
DLA    '@' '1' SP '0' SP '0' CR
```

12.3 Color Temperature Table

: 'U0B'(55H 30H 42H)

Definition : Sets the color temperature table

Command : 'U0B'(55H 30H 42H)

Parameter type : Special parameter (Refer to 7.3.2 Color Temperature Parameter.)

Reply time : 3seconds

Conditions :

Operation mode

Standby mode	Power ON mode	Cool-down mode	Emergency mode
X	O	X	X

Communication Examples

◇ When specifying "USER1" as the color temperature

```
CTLR  '!' '1' SP 'U0B' SP '2' CR
DLA   '@' '1' SP '0' CR
```

◇ When requesting current color temperature data (if color temperature is set to "D65")

```
CTLR  '?' '1' SP 'U0B' CR
DLA   '@' '1' SP '0' SP '0' CR
```

12.4 Color Temperature(RED)

: 'U0C'(55H 30H 43H)

Definition : Adjusts the color temperature(RED)

Command : 'U0C'(55H 30H 43H)

Parameter type : Numeric

Reply time : 3seconds

Conditions :

Operation mode

Standby mode	Power ON mode	Cool-down mode	Emergency mode
X	O	X	X

Communication Examples

- ◇ When specifying "-2" (decimal) as the color temperature(RED) adjust level

```
CTLR  '!' '1' SP 'U0C' SP 'FFFE' CR
DLA    '@' '1' SP '0' CR
```

- ◇ When requesting current color temperature(RED) adjust level data (if color temperature(RED) adjust level is set to "-128" (decimal))

```
CTLR  '?' '1' SP 'U0C' CR
DLA    '@' '1' SP '0' SP 'FF80' CR
```

12.5 Color Temperature(GREEN)

: 'U0D'(55H 30H 44H)

Definition : Adjusts the color temperature(GREEN)

Command : 'U0D'(55H 30H 44H)

Parameter type : Numeric

Reply time : 3seconds

Conditions :

Operation mode

Standby mode	Power ON mode	Cool-down mode	Emergency mode
X	O	X	X

Communication Examples

- ◇ When specifying "-2" (decimal) as the color temperature(GREEN) adjust level

```
CTLR  '!' '1' SP 'U0D' SP 'FFFE' CR
DLA   '@' '1' SP '0' CR
```

- ◇ When requesting current color temperature(GREEN) adjust level data (if color temperature(GREEN) adjust level is set to "-128" (decimal))

```
CTLR  '?' '1' SP 'U0D' CR
DLA   '@' '1' SP '0' SP 'FF80' CR
```

12.6 Color Temperature(BLUE)

: 'U0E'(55H 30H 45H)

Definition : Adjusts the color temperature(BLUE)

Command : 'U0E'(55H 30H 45H)

Parameter type : Numeric

Reply time : 3seconds

Conditions :

Operation mode

Standby mode	Power ON mode	Cool-down mode	Emergency mode
X	O	X	X

Communication Examples

- ◇ When specifying "-2" (decimal) as the color temperature(BLUE)adjust level

```
CTLR  '!' '1' SP 'U0E' SP 'FFFE' CR
DLA    '@' '1' SP '0' CR
```

- ◇ When requesting current color temperature(BLUE)adjust level data
(if color temperature(BLUE)adjust level is set to "-128" (decimal))

```
CTLR  '?' '1' SP 'U0E' CR
DLA    '@' '1' SP '0' SP 'FF80' CR
```

Definition : Controls the power

Command : ‘U0F’(55H 30H 46H)

Parameter type : ON/OFF

Reply time : POWER ON transmission 120seconds(*1)
POWER OFF transmission 3seconds(*2)

Conditions : No query

Operation mode

Standby mode	Power ON mode	Cool-down mode	Emergency mode
O	O	X	X

Communication Examples

◇ When turning the Projector’s power ON

```
CTLR  '!' '1' SP 'U0F' SP '1' CR
DLA   '@' '1' SP '0' CR
```

*1

When the POWER ON command is received, the Projector returns the Tally (Response) Data after completing all the POWER ON processing operations (lighting lamp, rotating fans, transmitting data, etc.). In most cases, the Tally (Response) Data should be returned within 35 to 40 seconds.

If it takes more time to light up or re-try is done due to internal error , these operations takes maximum around 120 seconds. (The Tally Data is returned within 120 seconds.)

*2

When the POWER OFF command is received during Power-ON mode, the Projector enters the cool-down mode (DLA-HD10K Series: for about 60 seconds) and continue cooling (DLA-HD10K Series: for about 60 seconds).

After cool-down mode is completed, the Projector automatically enters the stand-by mode. (For operation modes, refer to 10. Projector Operation Modes.)

POWER ON command cannot be accepted in the Cool-Down mode. If POWER ON is requested after POWER OFF command is sent, firstly the current operation mode should be asked and then if Standby Mode is confirmed, POWER ON command should be sent. (For the command to request the current operation mode, refer to 12.31 Operation Mode Query.)

12.8 MENU Auto OFF

: 'U10'(55H 31H 30H)

Definition : Controls the display menu auto-off function

Command : 'U10'(55H 31H 30H)

Parameter type : Special parameter (Refer to 7.3.3 Menu Display Auto OFF Parameter.)

Reply time : 3seconds

Conditions :

Operation mode

Standby mode	Power ON mode	Cool-down mode	Emergency mode
X	O	X	X

Communication Examples

- ◇ When setting the menu display auto off to 15 sec

```
CTLR  '!' '1' SP 'U10' SP '0' CR
DLA   '@' '1' SP '0' CR
```

- ◇ When requesting the current menu display auto-off setting (if the menu display auto off is set to ON)

```
CTLR  '?' '1' SP 'U10' CR
DLA   '@' '1' SP '0' SP '1' CR
```

12.9 Sleep Time

: 'U12'(55H 31H 32H)

Definition : Sets the sleep time

Command : 'U12'(55H 31H 32H)

Parameter type : (*)

Reply time : 3seconds

Conditions :

Operation mode

Standby mode	Power ON mode	Cool-down mode	Emergency mode
X	O	X	X

The "Sleep time" function automatically turns off the projector power if the no-signal status continues for a specified time.

*Available parameters

Sleep time can be set to any of the following:

15 min., 30 min., 60 min., and 0 min.

When the above times are represented as numerical parameters:

	Character	HEX
15min.	'000F'	30H 30H 30H 46H
30min.	'001E'	30H 30H 31H 45H
60min.	'003C'	30H 30H 33H 43H
0min.	'0000'	30H 30H 30H 30H

The sleep time function is disabled when the time is set to "0 min".

#Tally (Response) data format to current sleep time query

'@' '1' SP Normal Termination Status SP Parameter 1 SP Parameter 2 CR

Parameter 1 : Indicates the sleep time specified
(Refer to "Available parameters")

Parameter 2 : Indicates the remaining sleep time.
Parameter type is numeric.

Communication Examples

◇ When specifying "30 min." as the sleep time

CTLR '!' '1' SP 'U12' SP '001E' CR
DLA '@' '1' SP '0' CR

◇ When requesting the current sleep time setting (if the sleep time is set to "15 min." and the remaining time is 3 min.)

CTLR '?' '1' SP 'U12' CR
DLA '@' '1' SP '0' SP '000F' SP '0003' CR

Definition : Enlarges the screen size
 Command : 'U13'(55H 31H 33H)
 Parameter type : Special parameter (Refer to 7.3.4 ZOOM/FOCUS Parameter.)
 Reply time : 3seconds
 Conditions : No query
 Notes : It becomes an error when the "Zoom/Focus Lock" parameter is set to Lock.
 Also it becomes an error when HIDE is ON.

Operation mode

Standby mode	Power ON mode	Cool-down mode	Emergency mode
X	O	X	X

Communication Examples

```

CTRL  '!' '1' SP 'U13' SP '1' CR
DLA   '@' '1' SP '0' CR
  
```

```

CTRL  '!' '1' SP 'U13' SP '0' CR
DLA   '@' '1' SP '0' CR
  
```

* Be sure to transmit the STOP command after transmitting the START command.

Definition : Reduces the screen size

Command : ‘U14’(55H 31H 34H)

Parameter type : Special parameter (Refer to 7.3.4 ZOOM/FOCUS Parameter.)

Reply time : 3seconds

Conditions : No query

Notes : It becomes an error when the "Zoom/Focus Lock" parameter is set to Lock.
Also it becomes an error when HIDE is ON.

Operation mode

Standby mode	Power ON mode	Cool-down mode	Emergency mode
X	O	X	X

Communication Examples

```

CTRL  '!' '1' SP 'U14' SP '1' CR
DLA   '@' '1' SP '0' CR
    
```

```

CTRL  '!' '1' SP 'U14' SP '0' CR
DLA   '@' '1' SP '0' CR
    
```

* Be sure to transmit the STOP command after transmitting the START command.

Definition : Moves the focal point forward

Command : ‘U15’(55H 31H 35H)

Parameter type : Special parameter (Refer to 7.3.4 ZOOM/FOCUS Parameter.)

Reply time : 3seconds

Conditions : No query

Notes : It becomes an error when the "Zoom/Focus Lock" parameter is set to Lock.
Also it becomes an error when HIDE is ON.

Operation mode

Standby mode	Power ON mode	Cool-down mode	Emergency mode
X	O	X	X

Communication Examples

```
CTLR    '!' '1' SP 'U15' SP '1' CR
DLA     '@' '1' SP '0' CR
```

```
CTLR    '!' '1' SP 'U15' SP '0' CR
DLA     '@' '1' SP '0' CR
```

* Be sure to transmit the STOP command after transmitting the START command.

Definition : Moves the focal point back

Command : ‘U16’(55H 31H 36H)

Parameter type : Special parameter (Refer to 7.3.4 ZOOM/FOCUS Parameter.)

Reply time : 3seconds

Conditions : No query

Notes : It becomes an error when the "Zoom/Focus Lock" parameter is set to Lock.
Also it becomes an error when HIDE is ON.

Operation mode

Standby mode	Power ON mode	Cool-down mode	Emergency mode
X	O	X	X

Communication Examples

```

CTRL    '!' '1' SP 'U16' SP '1' CR
DLA     '@' '1' SP '0' CR
    
```

```

CTRL    '!' '1' SP 'U16' SP '0' CR
DLA     '@' '1' SP '0' CR
    
```

* Be sure to transmit the STOP command after transmitting the START command.

12.14 Right/Left Reverse

: 'U17'(55H 31H 37H)

Definition : Reverses the image horizontally

Command : 'U17'(55H 31H 37H)

Parameter type : ON/OFF

Reply time : 3seconds

Conditions :

Operation mode

Standby mode	Power ON mode	Cool-down mode	Emergency mode
X	O	X	X

Communication Examples

◇ When reversing the image horizontally (Right /Left reverse)

```
CTLR  '!' '1' SP 'U17' SP '1' CR
DLA    '@' '1' SP '0' CR
```

◇ When requesting the current R/L reverse setting (if the image is not reversed horizontally)

```
CTLR  '?' '1' SP 'U17' CR
DLA    '@' '1' SP '0' SP '0' CR
```

12.15 Top/Bottom Invert

: 'U18'(55H 31H 38H)

Definition : Inverts the image vertically

Command : 'U18'(55H 31H 38H)

Parameter type : ON/OFF

Reply time : 3seconds

Conditions :

Operation mode

Standby mode	Power ON mode	Cool-down mode	Emergency mode
X	O	X	X

Communication Examples

◇ When inverting the image vertically (Top/Bottom invert)

```
CTLR  '!' '1' SP 'U18' SP '1' CR
DLA   '@' '1' SP '0' CR
```

◇ When requesting the current Top/Bottom invert setting (if the image is not inverted vertically)

```
CTLR  '?' '1' SP 'U18' CR
DLA   '@' '1' SP '0' SP '0' CR
```

12.16 Transfer Rate

: 'U1B'(55H 31H 42H)

Definition : Controls the transfer rate for RS-232C

Command : 'U1B'(55H 31H 42H)

Parameter type : Special parameter(Refer to 7.3.5 Transfer Rate Parameter.)

Reply time : 3seconds

Conditions :

Operation mode

Standby mode	Power ON mode	Cool-down mode	Emergency mode
×	○	×	×

* After this command has been received and processed correctly, the Tally (Response) Data is returned at the new transfer rate.

Communication Examples

◇ When changing the transfer rate to "9600 bps" from the current setting of "19200 bps"

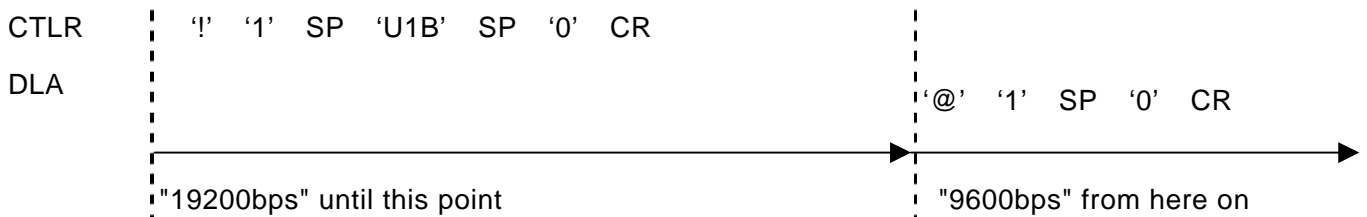

* The default transfer rate setting is "19200bps".

12.17 Lamp Time

: 'U1C'(55H 31H 43H)

Definition : Reset/check the lamp operation

Command : 'U1C'(55H 31H 43H)

Parameter type : (*)

Reply time : 3seconds

Conditions :

Operation mode

△ When resetting

Standby mode	Power ON mode	Cool-down mode	Emergency mode
O	X	X	X

△ When requesting current time

Standby mode	Power ON mode	Cool-down mode	Emergency mode
O	O	O	O

Data Format

△ Reset data format

'!' '1' SP 'U1C' SP Reset Parameter CR

(*)Reset parameter

Character	HEX
'[()]	5BH 28H 29H 5DH

* Never issue the Reset command unless the lamp has been replaced with a new one.

△ Tally (Response) data format when requesting current time

'@' '1' SP Normal Termination Status SP Parameter 1 SP Parameter 2 CR

(*)Parameter1

The Projector has an incremental counter which counts Lamp Operation Time at 1 time in every 4 minutes.

Parameter 1 shows this counter value. The parameter type is "numeric".

Actual lamp operating time is obtained by converting the Parameter 1 value into signed 2-byte binary hexadecimal and dividing it by 15.

(*)Parameter2

Parameter 2 shows whether the lamp replacement time is close or not, based on the following calculation:

$$(\text{Lamp service life} - 100 \text{ hours}) \leq \text{Lamp operating time} < \text{Lamp service life}$$

	Character	HEX
Lamp replacement time not close	'0'	30H
Lamp replacement time close	'1'	31H
Lamp life exceeded	'2'	32H

Communication Examples

◇ When requesting the current lamp operating time (if the lamp operating time is 150 hours)

```
CTLR    '?' '1' SP 'U1C' CR
DLA     '@' '1' SP '0' SP '08CA' SP '0' CR
```

12.18 ID**: 'U1D' (55H 31H 44H)**

Definition : Sets the ID for the Projector

Command : 'U1D' (55H 31H 44H)

Parameter type : Special parameter (Refer to 7.3.6 ID Parameter.)

Reply time : 3seconds

Conditions :

Operation mode

Standby mode	Power ON mode	Cool-down mode	Emergency mode
0	0	0	0

* When this command is received and processed correctly, the Tally (Response) Data is returned with the changed ID number.

Communication Examples

- ◇ When changing the ID to '7' from the current setting of '1'

```

CTRL  '!' '1' SP 'U1D' SP '7' CR
DLA   '@' '7' SP '0' CR

```

 Tally (Response) data is returned with New ID no.

- ◇ When requesting the ID setting (if the ID is set to "3")

```

CTRL  '?' '3' SP 'U1D' CR
DLA   '@' '3' SP '0' SP '3' CR

```

12.19 Gamma Table

: 'U73'(55H 37H 33H)

Definition : Sets the gamma table

Command : 'U73'(55H 37H 33H)

Parameter type : Special parameter (Refer to 7.3.7 Gamma Table Parameter.)

Reply time : 3seconds

Conditions :

Operation mode

Standby mode	Power ON mode	Cool-down mode	Emergency mode
X	O	X	X

Communication Examples

◇ When specifying "A" as the gamma table

```
CTLR    '!' '1' SP 'U73' SP '1' CR
DLA     '@' '1' SP '0' CR
```

◇ When requesting current gamma table data (if gamma table is set to "NORMAL")

```
CTLR    '?' '1' SP 'U73' CR
DLA     '@' '1' SP '0' SP '0' CR
```

12.20 Mask

: 'UA0'(55H 41H 30H)

Definition : Sets the mask

Command : 'UA0'(55H 41H 30H)

Parameter type : Special parameter (Refer to 7.3.8 Mask Parameter.)

Reply time : 3seconds

Conditions :

Operation mode

Standby mode	Power ON mode	Cool-down mode	Emergency mode
X	O	X	X

Communication Examples

◇ When specifying "2.5%" as the mask

```
CTLR  '!' '1' SP 'UA0' SP '1' CR
DLA   '@' '1' SP '0' CR
```

◇ When requesting current mask data (if mask is set to "0%")

```
CTLR  '?' '1' SP 'UA0' CR
DLA   '@' '1' SP '0' SP '0' CR
```

12.21 Test Pattern

: 'UA1'(55H 41H 31H)

Definition : Sets the test pattern

Command : 'UA1'(55H 41H 31H)

Parameter type : Special parameter (Refer to 7.3.9 Test Pattern Parameter.)

Reply time : 3seconds

Conditions :

Operation mode

Standby mode	Power ON mode	Cool-down mode	Emergency mode
X	O	X	X

Communication Examples

- ◇ When specifying "Cross Hatch(only G)" as the test pattern

```
CTLR  '!' '1' SP 'UA1' SP 'A' CR
DLA   '@' '1' SP '0' CR
```

- ◇ When requesting current test pattern data (if Test Pattern is set to "OFF")

```
CTLR  '?' '1' SP 'UA1' CR
DLA   '@' '1' SP '0' SP '0' CR
```

12.22 Picture Shift

: 'UA2'(55H 41H 32H)

Definition : Sets the vertical picture shift

Command : 'UA2'(55H 41H 32H)

Parameter type : Numeric

Reply time : 3seconds

Conditions :

Operation mode

Standby mode	Power ON mode	Cool-down mode	Emergency mode
X	O	X	X

Communication Examples

◇ When specifying 1 as the picture shift

```
CTLR  '!' '1' SP 'UA2' SP '0001' CR
DLA   '@' '1' SP '0' CR
```

◇ When requesting current picture shift data (if picture shift is set to -1)

```
CTLR  '?' '1' SP 'UA2' CR
DLA   '@' '1' SP '0' SP 'FFFF' CR
```

12.23 Zoom/Focus Lock

: 'UA9'(55H 41H 39H)

Definition : Sets the Zoom/Focus function to Lock or Unlock.

Command : 'UA9'(55H 41H 39H)

Parameter type : Special parameter (Refer to 7.3.10 Zoom/Focus Lock Parameter.)

Reply time : 3seconds

Conditions :

Operation mode

Standby mode	Power ON mode	Cool-down mode	Emergency mode
X	O	X	X

Communication Examples

◇ When specifying "Unlock" as the Zoom/Focus Lock

```
CTLR    '!' '1' SP 'UA9' SP '0' CR
DLA     '@' '1' SP '0' CR
```

◇ When requesting current Zoom/Focus Lock (if Zoom/Focus Lock is set to "Lock")

```
CTLR    '?' '1' SP 'UA9' CR
DLA     '@' '1' SP '0' SP '1' CR
```

12.24 Power Save

: 'UAA'(55H 41H 41H)

Definition : Controls Power Save mode.

Command : 'UAA'(55H 41H 41H)

Parameter type : ON/OFF

Reply time : 3seconds

Conditions :

Notes : It cannot change for about 1 minute immediately after changing by power-on or this command. When it changes, an error occurs.

Operation mode

Standby mode	Power ON mode	Cool-down mode	Emergency mode
X	O	X	X

Communication Examples

- ◇ When setting the Power Save mode to ON

```
CTLR  '!' '1' SP 'UAA' SP '1' CR
DLA   '@' '1' SP '0' CR
```

- ◇ When requesting current Power Save mode (if Power Save mode is OFF)

```
CTLR  '?' '1' SP 'UAA' CR
DLA   '@' '1' SP '0' SP '0' CR
```

12.25 Horizontal Pixel Adjust (RED)

: 'UB0'(55H 42H 30H)

Definition : Adjusts the Horizontal Pixel Adjust (RED).

Command : 'UB0'(55H 42H 30H)

Parameter type : Special parameter (Refer to 7.3.12 Horizontal Pixel Adjust Parameter.)

Reply time : 3seconds

Conditions :

Operation mode

Standby mode	Power ON mode	Cool-down mode	Emergency mode
X	O	X	X

Communication Examples

- ◇ When specifying "2" (decimal) as the Horizontal Pixel Adjust (RED) level.

```
CTLR    '!' '1' SP 'UB0' SP '2' CR
DLA     '@' '1' SP '0' CR
```

- ◇ When requesting current Horizontal Pixel Adjust (RED) level data (if Horizontal Pixel Adjust (RED) level is set to "6" (decimal))

```
CTLR    '?' '1' SP 'UB0' CR
DLA     '@' '1' SP '0' SP '6' CR
```

12.26 Horizontal Pixel Adjust (GREEN)

: 'UB1'(55H 42H 31H)

Definition : Adjusts the Horizontal Pixel Adjust (GREEN).

Command : 'UB1'(55H 42H 31H)

Parameter type : Special parameter (Refer to 7.3.12 Horizontal Pixel Adjust Parameter.)

Reply time : 3seconds

Conditions :

Operation mode

Standby mode	Power ON mode	Cool-down mode	Emergency mode
X	O	X	X

Communication Examples

- ◇ When specifying "2" (decimal) as the Horizontal Pixel Adjust (GREEN) level.

```
CTLR    '!' '1' SP 'UB1' SP '2' CR
DLA     '@' '1' SP '0' CR
```

- ◇ When requesting current Horizontal Pixel Adjust (GREEN) level data (if Horizontal Pixel Adjust (GREEN) level is set to "6" (decimal))

```
CTLR    '?' '1' SP 'UB1' CR
DLA     '@' '1' SP '0' SP '6' CR
```

12.27 Horizontal Pixel Adjust (BLUE)

: 'UB2'(55H 42H 32H)

Definition : Adjusts the Horizontal Pixel Adjust (BLUE).

Command : 'UB2'(55H 42H 32H)

Parameter type : Special parameter (Refer to 7.3.12 Horizontal Pixel Adjust Parameter.)

Reply time : 3seconds

Conditions :

Operation mode

Standby mode	Power ON mode	Cool-down mode	Emergency mode
X	O	X	X

Communication Examples

- ◇ When specifying "2" (decimal) as the Horizontal Pixel Adjust (BLUE) level.

```
CTLR    '!' '1' SP 'UB2' SP '2' CR
DLA     '@' '1' SP '0' CR
```

- ◇ When requesting current Horizontal Pixel Adjust (BLUE) level data (if Horizontal Pixel Adjust (BLUE) level is set to "6" (decimal))

```
CTLR    '?' '1' SP 'UB2' CR
DLA     '@' '1' SP '0' SP '6' CR
```

12.28 Vertical Pixel Adjust (RED)

: 'UB3'(55H 42H 33H)

Definition : Adjusts the Vertical Pixel Adjust (RED).

Command : 'UB3'(55H 42H 33H)

Parameter type : Special parameter (Refer to 7.3.13 Vertical Pixel Adjust Parameter.)

Reply time : 3seconds

Conditions :

Operation mode

Standby mode	Power ON mode	Cool-down mode	Emergency mode
X	O	X	X

Communication Examples

- ◇ When specifying "2" (decimal) as the Vertical Pixel Adjust (RED) level.

```
CTLR    '!' '1' SP 'UB3' SP '2' CR
DLA     '@' '1' SP '0' CR
```

- ◇ When requesting current Vertical Pixel Adjust (RED) level data (if Vertical Pixel Adjust (RED) level is set to "6" (decimal))

```
CTLR    '?' '1' SP 'UB3' CR
DLA     '@' '1' SP '0' SP '6' CR
```

12.29 Vertical Pixel Adjust (GREEN)**: 'UB4'(55H 42H 34H)**

Definition : Adjusts the Vertical Pixel Adjust (GREEN).

Command : 'UB4'(55H 42H 34H)

Parameter type : Special parameter (Refer to 7.3.13 Vertical Pixel Adjust Parameter.)

Reply time : 3seconds

Conditions :

Operation mode

Standby mode	Power ON mode	Cool-down mode	Emergency mode
X	O	X	X

Communication Examples

- ◇ When specifying "2" (decimal) as the Vertical Pixel Adjust (GREEN) level.

```

CTRL  '!' '1' SP 'UB4' SP '2' CR
DLA   '@' '1' SP '0' CR

```

- ◇ When requesting current Vertical Pixel Adjust (GREEN) level data (if Vertical Pixel Adjust (GREEN) level is set to "6" (decimal))

```

CTRL  '?' '1' SP 'UB4' CR
DLA   '@' '1' SP '0' SP '6' CR

```

12.30 Vertical Pixel Adjust (BLUE)

: 'UB5'(55H 42H 35H)

Definition : Adjusts the Vertical Pixel Adjust (BLUE).

Command : 'UB5'(55H 42H 35H)

Parameter type : Special parameter (Refer to 7.3.13 Vertical Pixel Adjust Parameter.)

Reply time : 3seconds

Conditions :

Operation mode

Standby mode	Power ON mode	Cool-down mode	Emergency mode
X	O	X	X

Communication Examples

- ◇ When specifying "2" (decimal) as the Vertical Pixel Adjust (BLUE) level.

```
CTLR    '!' '1' SP 'UB5' SP '2' CR
DLA     '@' '1' SP '0' CR
```

- ◇ When requesting current Vertical Pixel Adjust (BLUE) level data (if Vertical Pixel Adjust (BLUE) level is set to "6" (decimal))

```
CTLR    '?' '1' SP 'UB5' CR
DLA     '@' '1' SP '0' SP '6' CR
```

12.31 Operation Mode Query

: 'Z03'(5AH 30H 33H)

Definition : Requests current operation mode

Command : 'Z03'(5AH 30H 33H)

Parameter type : Special parameter(Refer to 7.3.11 Projector Operation Mode Parameter.)

Reply time : 3seconds

Conditions : Query only

Operation mode

Standby mode	Power ON mode	Cool-down mode	Emergency mode
O	O	O	O

When the POWER OFF command is received in the Power ON mode, the Projector first enters the Cool-Down mode, then automatically enters the Standby mode.

(For information on each operation mode, refer to 10. Projector Operation Modes.)

POWER ON command cannot be accepted in the Cool-Down mode. If POWER ON is requested after POWER OFF command is sent, firstly the current operation mode should be asked and then if Standby Mode is confirmed, POWER ON command should be sent.

Communication Examples

◇ When requesting the current operation mode(if the Projector is in the standby mode)

```
CTLR    '?' '1' SP 'Z03' CR
DLA     '@' '1' SP '0' SP '0000' CR
```

12.32 Source Query

: 'Z05'(5AH 30H 35H)

Definition : Asks for the Source setting actually assigned on the Projector.

Command : 'Z05'(5AH 30H 35H)

Parameter type : (Refer to 11.1 Projector Sources and Source Numbers.)

Reply time : 3seconds

Conditions : Query only

Operation mode

Standby mode	Power ON mode	Cool-down mode	Emergency mode
X	O	X	X

Communication Example

- ◇ When requesting the current Source setting actually assigned on the Projector (if 1080p60 is actually assigned)

```
CTLR  '?' '1' SP 'Z05' CR
DLA   '@' '1' SP '0' SP '10' CR
```

12.33 Projection Model Query

: 'Z0A'(5AH 30H 41H)

Definition : Obtains projector model and software version information.

Command : 'Z0A'(5AH 30H 41H)

Parameter type : (*)

Reply time : 3seconds

Conditions : Query only

Operation mode

Standby mode	Power ON mode	Cool-down mode	Emergency mode
O	O	O	X

* Model status data format

- ◇ Requesting current projector model status

'?' '1' SP 'Z0A' CR

Parameter : None

- ◇ Tally (response) data format to query

'@' '1' SP Normal Termination Status SP **Parameter** CR

Parameter : 13 byte ASCII characters are used for Model and Software version information.

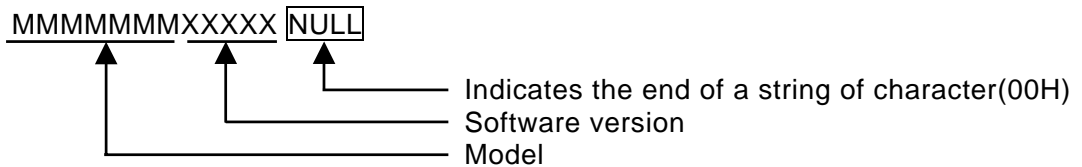

Model	HEX	Definition
'HD10K--'	48H 44H 31H 30H 4BH 2DH 2DH	DLA-HD10K Series

Communication Example

- ◇ When the projector is a HD10K Series projector with software version 1.3.4

CTLR '?' '1' SP 'Z0A' CR

DLA '@' '1' SP '0' SP 'HD10K---00134' NULL CR

13. APPENDIX

13.1 External Control Command List

Command	Character	HEX
Hide	'U00'	55H 30H 30H
Back Color	'U01'	55H 30H 31H
Color Temperature Table	'U0B'	55H 30H 42H
Color Temperature (RED)	'U0C'	55H 30H 43H
Color Temperature (GREEN)	'U0D'	55H 30H 44H
Color Temperature (BLUE)	'U0E'	55H 30H 45H
Power	'U0F'	55H 30H 46H
Menu Auto Off	'U10'	55H 31H 30H
Sleep Time	'U12'	55H 31H 32H
Zoom W	'U13'	55H 31H 33H
Zoom T	'U14'	55H 31H 34H
Focus +	'U15'	55H 31H 35H
Focus -	'U16'	55H 31H 36H
Right/Left Reverse	'U17'	55H 31H 37H
Top/Bottom Invert	'U18'	55H 31H 38H
Transfer Rate	'U1B'	55H 31H 42H
Lamp Time	'U1C'	55H 31H 43H
ID	'U1D'	55H 31H 44H
Gamma Table	'U73'	55H 37H 33H
Mask	'UA0'	55H 41H 30H
Test Pattern	'UA1'	55H 41H 31H
Picture Shift	'UA2'	55H 41H 32H
Zoom/Focus Lock	'UA9'	55H 41H 39H
Power Save	'UAA'	55H 41H 41H
Horizontal Pixel Adjust (RED)	'UB0'	55H 42H 30H

Horizontal Pixel Adjust (GREEN)	'UB1'	55H 42H 31H
Horizontal Pixel Adjust (BLUE)	'UB2'	55H 42H 32H
Vertical Pixel Adjust (RED)	'UB3'	55H 42H 33H
Vertical Pixel Adjust (GREEN)	'UB4'	55H 42H 34H
Vertical Pixel Adjust (BLUE)	'UB5'	55H 42H 35H
Operation Mode Query	'Z03'	5AH 30H 33H
Source Query	'Z05'	5AH 30H 35H
Model Status	'Z0A'	5AH 30H 41H

13.2 RS-232C Port Pin Configuration

RS-232C Control Port			
D-SUB 9-pin (Male)	Pin No.	Signal	Definition
	1	N/A	Not used
	2	RxD(RD)	Receive data
	3	TxD(SD)	Transmit data
	4	N/A	Not used
	5	GND	GND
	6	N/A	Not used
	7	N/A	Not used
	8	N/A	Not used
	9	N/A	Not used

13.3 Flow chart of "Power ON Control"

We mention an example of flow chart as below. The commands printed in the chart are in the case of "ID = 1". For details about an ID, refer to "12.18 ID".

EXAMPLE

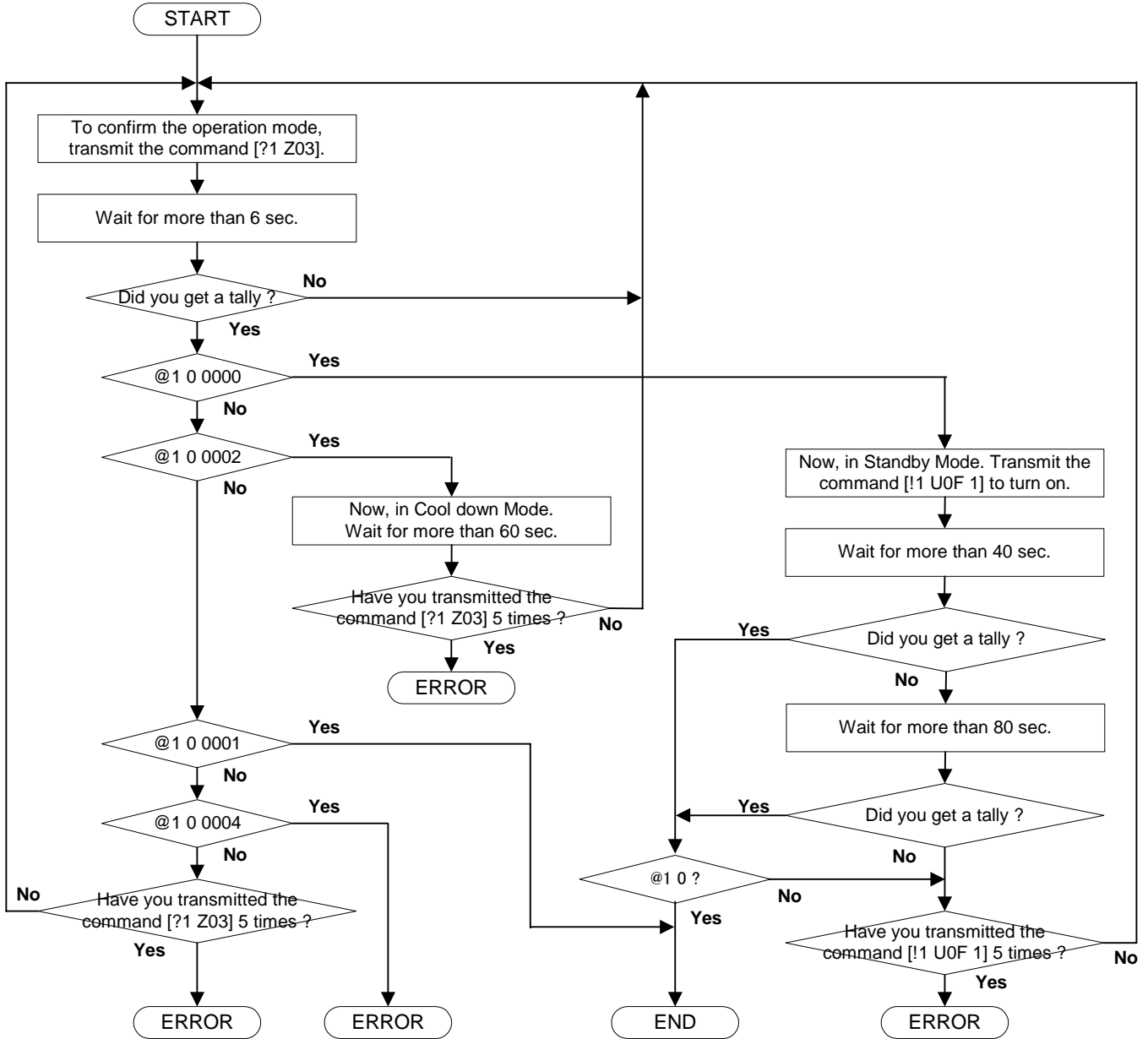

13.4 Flow chart of "Power OFF Control"

We mention an example of flow chart as below which diagrams through "Cool-down mode" up to "Standby mode". The commands printed in the chart are in the case of "ID = 1". For details about an ID, refer to "12.18 ID".

EXAMPLE

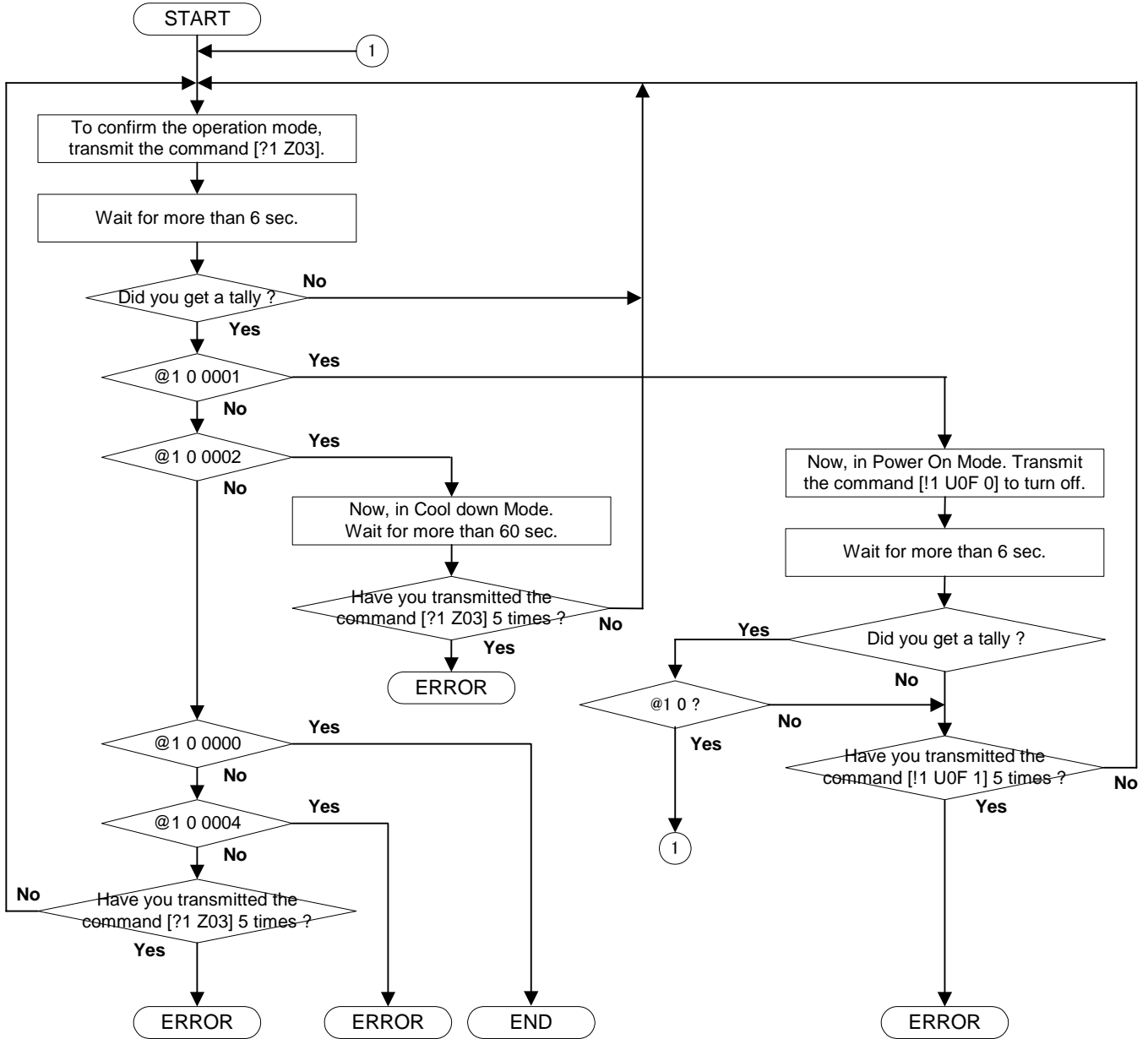

13.5 Revision History

Version 1.0

First Release

Version 1.1

9.1 'E02' was added as Internal Error Data.

Version 1.2

12.25-12.30 Parameter of Horizontal Pixel Adjust and Vertical Pixel Adjust was corrected to a special parameter.